

# Resource-Efficient Class-based Flow Mobility Support in PMIPv6 domain

Jiwon Jang<sup>\*</sup>, Seil Jeon<sup>\*</sup>, Younghan Kim<sup>\*#</sup>, and Jinwoo Park<sup>†</sup>

<sup>\*</sup>School of Electronic Engineering, Soongsil University, Dongjak-gu, Seoul, 156-743, Korea  
{jwjang84, sijeon, yhkim}@dsn.ssu.ac.kr

<sup>†</sup>Department of Electronics and Computer Engineering, Korea University, Seongbuk-ku, Seoul, 136-713, Korea  
jwpark@korea.ac.kr

**Abstract**— Flow-based mobility support is becoming increasingly common in multi-interface environments because it provides flexible network selection per application flow and better network experience for mobile users. Recently, several drafts related to flow mobility have been being handled in IETF, but mobility handling per individual flow leads to signaling overhead and power consumption issues because individual flow always wants to have the best connected service with all the available network interfaces in its own demand. Power saving communication is becoming a worldwide issue in the mobile communication field. To make resource-efficient flow mobility, we propose a class-based flow mobility (CFM) mechanism. Through the performance analysis and results, we confirm that a CFM mechanism is superior to an individual flow mobility (IFM) mechanism in terms of signaling overhead and power consumption.

**Keywords** - Proxy Mobile IPv6; PMIPv6; flow mobility; class-based flow mobility

## I. INTRODUCTION

Multi-interface on mobile devices is becoming increasingly common. In such an environment, flow handover, which controls individual application flows from one interface to another even when the mobile node (MN) does not physically switch its network interface, is becoming the one of the most critical issues in the research field of next generation wireless network. Flow handover can provide a better network experience for end users and can also enable a network operator to balance the load appropriately depending on the availability of network capacity.

For this reason, in the Internet Engineering Task Force (IETF), several proposals [1][2] for flow handover are being handled over Proxy Mobile IPv6 (PMIPv6) [3] to provide network-based mobility management support to an MN without requiring its IP mobility-related signaling. However, it has several drawbacks. First, it can easily bring about signaling overhead that enables all flows to have the best connected network. Second, it can quickly run out of battery power because it preferentially considers flows' performance with all the available network interfaces.

To complement these drawbacks of the individual flow mobility mechanism (IFM), we propose a class-based flow mobility (CFM) mechanism by classifying the application flows into groups and performing group-based flow handling. Through the performance analysis, we confirm that CFM is

more resource-efficient than IFM in terms of signaling overhead and power consumption.

The rest of this paper is organized as follows. In Section II, we explain the IFM mechanisms proposed in IETF. In Section III, we propose CFM mechanism. Section IV evaluates a performance of IFM and CFM mechanism based on an analytical model and presents the numerical results. In Section V, we offer a conclusion.

## II. FLOW MOBILITY IN PMIPv6

Proxy Mobile IPv6 (PMIPv6) provides network-based mobility management for an MN that is connecting to a PMIPv6 domain. PMIPv6 introduces two new functional entities: the local mobility anchor (LMA) and the mobile access gateway (MAG). The MAG detects the MN's movement and provides IP connectivity. The LMA assigns one or more home network prefixes (HNPs) to the MN and is the topological anchor for all traffic belonging to the MN. The PMIPv6 allows MNs to connect to the network through multiple interfaces for simultaneous access. The MN can send packets simultaneously to the PMIPv6 domain over multiple interfaces. However, for supporting flow handover over PMIPv6, two issues should be resolved.

First, an HNP is assigned to one interface at a time because PMIPv6 employs per-MN prefix model. Therefore, when the flow mobility occurs, some of these flows are moved to a new interface while the other flows remain transmitted via the old interface. For keeping the sessions, the HNP should be assigned to multiple interfaces simultaneously. To solve the issue, a logical interface-based approach is proposed as one option to hide the changes at the physical interfaces from the IP layer [4].

Second, the PMIPv6 does not support flow-based routing because the LMA performs an HNP-based packet routing. To make packets route at the flow-based level, the LMA binding cache is required to be extended [2]. By applying these solutions, the flow handover can provide flexible network selection and better network experience for end users. However, two representative flow mobility solutions proposed in IETF do not consider signaling overhead and battery power that is consumed to control all the flows. Thus, it leads to a waste of resource for an MN and an access network. To complement these drawbacks, a novel flow handover scheme is required.

#Corresponding author

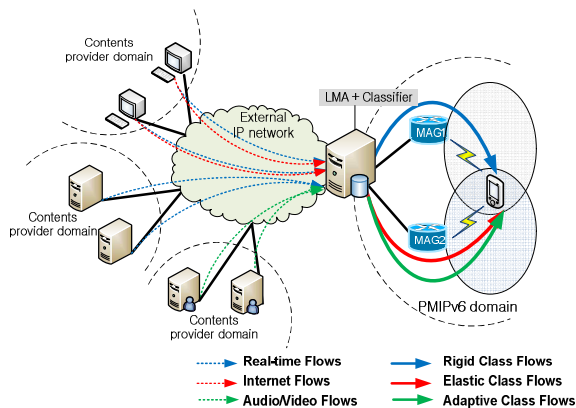

Figure 1. Class-based flow mobility reference network model

III. CLASS-BASED FLOW MOBILITY (CFM) SCHEME

The CFM scheme maximizes the user's performance and minimizes signaling overhead and power consumption. Specifically, it classifies and splits application flows of same class into groups, then it performs CFM scheme targeting a same kinds of class flows.

To classify flows according to application type, a classifier is required within LMA as shown in Figure 1. Several flows are divided into three categories: rigid, elastic, and adaptive. Generally, real-time services such as VoIP are classified as rigid class. Traditional Internet flows, such as FTP and Web are classified as elastic class. And delay-adaptive audio/video streaming or rate-adaptive multimedia flows belong to the adaptive class [5]. Such classification methods are divided into header-based and payload-based methods. Recent services are frequently running on non-standard ports, so the header-based classification method that checks the packet header is difficult to classify correctly. On the contrary, the payload-based classification method that checks the entire protocol payload requires a lot of computational power, and leads to significant overhead [6]. Therefore, we propose a new flow classification algorithm to support the CFM as shown in Figure 2.

To facilitate class-based flow forwarding, several binding entry information is needed on the LMA; therefore, class binding entry (CBE) consisting of three attributes such as class ID, QoS Parameter, and binding ID and data structure are offered, as shown in Figure 3.

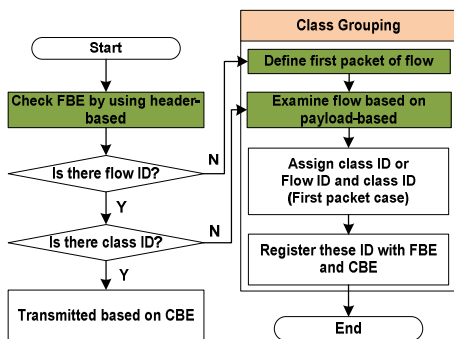

Figure 2. Proposed classification algorithm

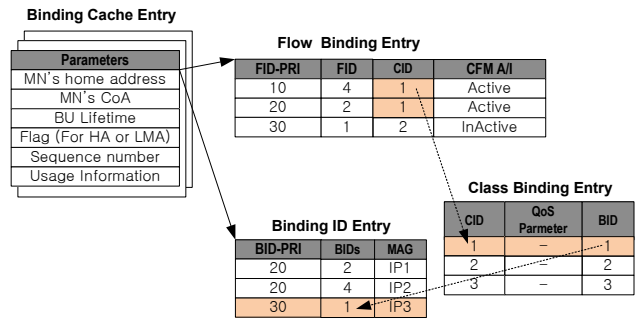

Figure 3. Extended binding cache entry for proposed CFM

The classifier assigns the flow ID and class ID. Assigned IDs are managed within flow binding entry (FBE) and CBE. When flow handover occurs, the same kind of class flows are moved to target MAG through confirming CBE.

In CFM, because each flow within the same class has its own requirement, moving these flows to the single target network with meeting the requirement requires the appropriate algorithm. As one of the solutions for this requirement, we can use the fairness algorithm proposed in [7]. From this solution, we can decide whether to move grouped flows to another interface.

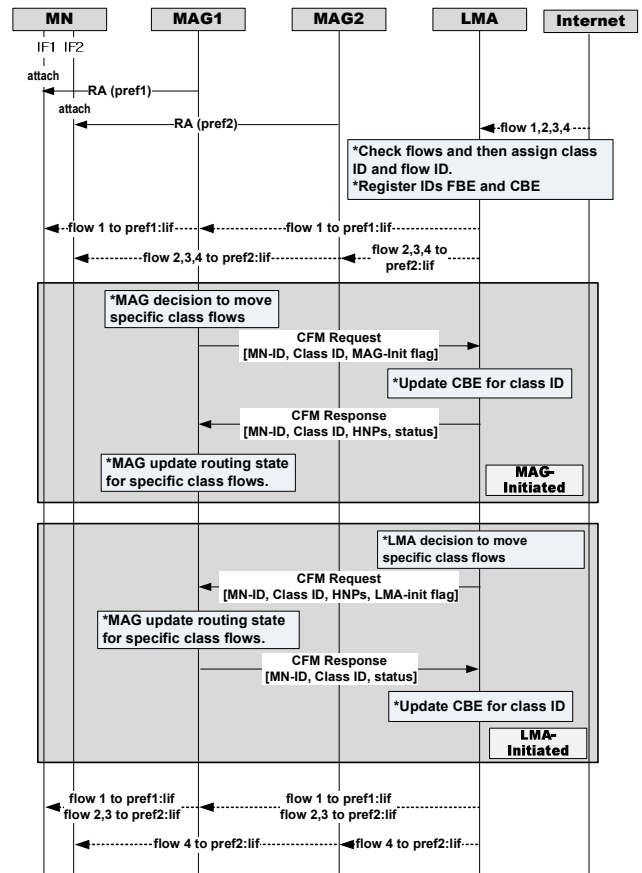

Figure 4. LMA and MAG-Initiated CFM procedure

After performing flow classification and enabling class-based flow forwarding, and deciding fairness values, the flow information such as MN-ID, class-ID, and HNP between MAG and using class flow mobility request/response (CFM Request/Response) is announced. These signaling methods are operated differently for two cases (e.g. MAG-initiated and LMA-initiated), as shown in Figure 4 in details. Flows 2 and 3 belong to the same class.

#### IV. PERFORMANCE ANALYSIS AND NUMERICAL RESULTS

This Section presents a performance analysis of the CFM and the IFM mechanisms. For ease of analytical modeling, we assume that the network is always possible to admit all flows and the bandwidth required for individual flow within same class is equal. Under these assumptions, we analyze signaling overhead and power consumption of two mechanisms. And we offer the numerical results by comparing their performances.

##### A. System Model

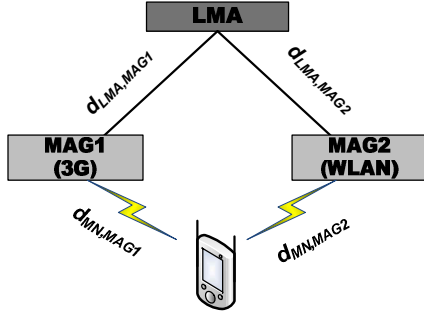

Figure 5. Network topology model for performance analysis

Figure 5 illustrates the network model for performance analysis.  $d_{x-y}$  denotes the hop distance between two network entities  $x$  and  $y$ . We define  $\mu_s$  and  $\lambda_s$  as the cell-crossing rate for which the MN still keeps its residence in the same domain and session arrival rate. From them, we obtain the average number of movement,  $E(N_s)$  and express it as follows:

$$E(N_s) = \mu_s / \lambda_s. \quad (1)$$

##### B. Signaling Cost

$C_z$  denotes signaling cost to conduct flow handover operation of  $z$  scheme. And, the signaling cost is defined as product of hop distance and signaling message generated between LMA and MAG, considering MN's movement and processing cost issued from MAG, LMA. The signaling cost for CFM and IFM are expressed by

$$C_{CFM} = E(N_s) \cdot (\tau \cdot (d_{LMA,MAG2} \cdot L_{CFM \text{ Req}}) + P_R \cdot (d_{LMA,MAG2} - 1) + P_{MAG2} + \tau \cdot (d_{LMA,MAG2} \cdot L_{CFM \text{ Res}}) + P_R \cdot (d_{LMA,MAG2} - 1) + P_{MAG2}), \quad (2)$$

$$C_{IFM} = E(N_s) \cdot (\tau \cdot (d_{LMA,MAG2} \cdot L_{PBA}) + P_R \cdot (d_{LMA,MAG2} - 1) + P_{MAG2} + 2 \cdot P_{LMA} + P_{MAG1} + \tau \cdot (d_{LMA,MAG1} \cdot L_{PBA}) + P_R \cdot (d_{LMA,MAG1} - 1) + P_{LMA}), \quad (3)$$

where  $\tau$  and  $L_m$  are the unit transmission cost over wired link and the amount of the signaling message, respectively.  $P_R$  is the routing processing cost between routers, while  $P_{LMA}$  and  $P_{MAG}$  denote the processing cost required in LMA and MAG.

##### C. Power Consumption Cost

The power consumption cost is defined as the amount of power consumed in MN. It is dependent on cell paging, scanning, beacon operation, time of data communication, and the amount of data being received (or sent) by a particular type of application. It is computed using the sum of time of data communication and amount of data. It can be expressed by the following:

$$P = r_d \cdot d + r_t \cdot t + c. \quad (4)$$

Here,  $r_d$  and  $d$  refer to the power consumption rate for data and the amount of data, respectively.  $r_t$  and  $t$  are the power consumption per unit time and the transaction time, respectively, and  $P$  and  $c$  refer to the total power consumption cost to receive  $d$  amount of data. Two kinds of application types such as video streaming or VoIP are considered. Corresponding equation is derived from [9].

$$P = t \cdot [r_t + R_{req} \cdot r_d] + c, \quad (5)$$

where  $R_{req}$  is the data rate required by the specific session.

##### D. Numerical Results

We employ some of parameter values used in the literature [8] [9], which are shown in Tables I and II.

Figure 6 shows the signaling cost of IFM and CFM as MN's velocity increases. In the case of CFM, it is assumed that the flows are grouped within the same class. The result shows that IFM increases proportionally to the number of flows, and that the cost of CFM is lower than that of IFM, regardless of the number of flows.  $d_{LMA,MAG1}$  and  $d_{LMA,MAG2}$  are 4, and  $d_{MN,MAG1}$  and  $d_{MN,MAG2}$  are 1, respectively.

Figure 7 illustrates power consumption according to four case scenarios. It is assumed that an MN has 1 VoIP and 2 video streaming flows where packet arrival rate for VoIP and video are 80 Kbyte/s and 200~300 Kbyte/s, respectively. In case 3, the MN uses 3 sessions through 3G interface when a single video streaming session is moved to the WLAN interface at 60 seconds.

TABLE I. PARAMETERS USED FOR NUMERICAL RESULTS

Parameters	Values	Parameters	Values
$\tau$	0.5	$P_R$	0.008s
$L_m$	100 (byte)	$\mu_s$	0.01
$\lambda_s$	10	$t$	30~150s

TABLE II. POWER CONSUMPTION IN 3G/WLAN INTERFACE

Mode	Parameters	
	$r_r$ (W)	$r_d$ (J/Kbyte)
3G	0.45	0.001
WLAN	0.9	4.12E-04

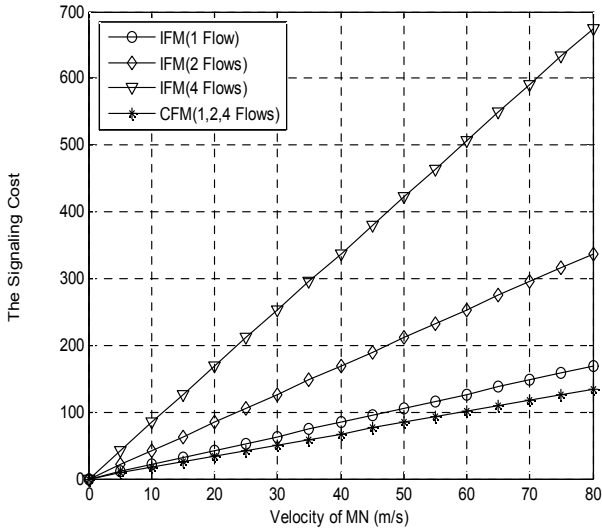

Figure 6. Signaling cost as MN's velocity increases

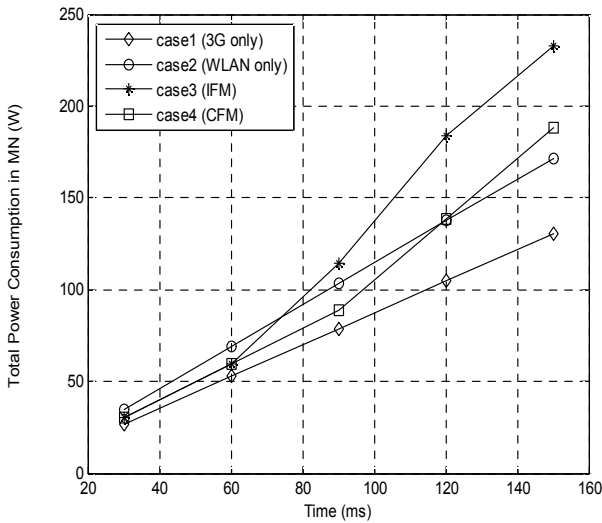

Figure 7. Power consumption cost

At this time, the power consumption cost increases significantly. Then, at 90 seconds, the other video streaming session is also moved to the WLAN interface. At that time, the power consumption cost becomes much higher than in Cases 1 and 2 because WLAN and 3G interfaces are used at the same time. In Case 4, two video sessions of same class are moved to the WLAN interface at 90 seconds using the

fairness algorithm, and the power consumption cost rapidly increases. From these results using simple cases, we confirm that the CFM can avoid unnecessary signaling overhead in network side and also reduce power consumption in host side.

V. CONCLUSION

Flow mobility is an effective mobility technique that can provide flexible network selection per application flow and better network experience for mobile users. But individual flow mobility schemes introduced in IETF bring about signaling overhead and power consumption issues due to the pursuit of only the performance of individual flow with high priority.

To solve these issues, we propose a CFM mechanism, which classifies the application flows into groups and performs group-based flow handover.

Through the performance analysis, we confirm that the CFM mechanism is more resource-efficient than the IFM mechanism in terms of signaling overhead and power consumption. For future work, we will evaluate additional performance factor by using simulation.

ACKNOWLEDGMENT

This work was partially supported by the MKE(The Ministry of Knowledge Economy), Korea, under the "program for CITG" support program supervised by the NIPA(National IT Industry Promotion Agency), and the IT R&D program of MKE/KEIT [KI001822, Research on Ubiquitous Mobility Management Methods for Higher Service Availability].

REFERENCES

- [1] C.J. Bernardos, M. Jeyatharan, R.Koodli, T. Melia, and F. Xia, "Proxy Mobile IPv6 Extensions to Support Flow Mobility," draft-bernardos-netext-pmipv6-flowmob-00, July, 2010.
- [2] T. Tran, Y. Hong, and Y. Han, "Flow Tracking Procedure for PMIPv6," draft-trung-netext-flow-tracking-01, July, 2010.
- [3] S. Gundavelli, K. Leung, V. Devarapalli, K. Chowdhury, and B. Patil, "Proxy Mobile IPv6," RFC 5213, August 2008.
- [4] T. Melia and S. Gundavelli, "Logical Interface Support for Multi-mode IP Hosts," draft-ietf-netext-logical-interface-support-00, August, 2010.
- [5] L. Breslau and S. Shenker "Best Effort versus Reservation: A Simple Comparative Analysis", ACM Computer Communications Review vol. 28, no. 4, pp.131-143, 1998.
- [6] A. W. Moore and K. Papagiannaki, "Toward the Accurate Identification of Network Applications," LNCS 3431, pp. 41-54, 2005.
- [7] M. Kim and S. Lee, "Load Balancing and Its Performance Evaluation for Layer 3 and IEEE 802.21 Frameworks in PMIPv6-based Wireless Networks," Wireless Communications and Mobile Computing, vol. 10, no. 11, pp.1431-1443, November 2010.
- [8] S. Jeon, N. Kang, Y. Kim and W. Yoon, "Enhanced PMIPv6 Route Optimization Handover," IEICE Transactions on Communications vol. E91-B, no.11, pp. 3715-3718, November 2008.
- [9] K.Mahmud, M. Inoue, H. Murakami, M. Hasegawa, and H. Morikawa, "Energy Consumption Measurement of Wireless Interfaces in Multi-Service User Terminals for Heterogeneous Wireless Networks," IEICE Transactions on Communications, vol. E88-B, no.3, pp. 1097-1110, March 2005.