

Printed Textile Touchpad

Josue Ferri, Jorge Moreno, Gabriel Martinez
 Smart Textiles and ICT Solutions Research Group
 Textile Research Institute (AITEX)-Alicante, Spain
 e-mail: josue.ferri@aitex.es, jmoreno@aitex.es,
 gmartinez@aitex.es

Jose Vicente Lidón-Roger, Eduardo Garcia-Breijo
 Instituto Interuniversitario de Investigación de
 Reconocimiento Molecular y Desarrollo Tecnológico
 (IDM), Universitat Politècnica de València, Universitat de
 València-Valencia, Spain
 e-mail: jvlidon@eln.upv.es, egarciab@eln.upv.es

Abstract— The touchpad is a typical 2D gesture detection example of interface devices used on wearable technology. In this work, a textile touchpad based on a diamond pattern design has been developed by using screen-printing technology. In order to obtain the best configuration, two different architectures have been used. Prototypes have been tested by using a specific controller for projected capacitive (pro-cap) technologies. We show a simple device, inexpensive, easy to make and use with textile.

Keywords-wearable sensing; touchpad; textile; screen-printing technology.

I. INTRODUCTION

Wearable devices are increasingly being developed due to their flexibility and portability. Among all wearable devices, the interface devices can be considered as essential tools for allowing the user to interact with other devices both external and wearable [1]. Buttons, touchpads, keyboards are example of interfaces. The common characteristics of all of them are the requirement of a large sensor area and a stretchable or flexible format; the first in order to detect the fingers [2] and the second in order to follow the movement of human body [3]. Several designs and techniques have been used but these can be divided into two main techniques: by using fibers and weaving the pattern or by using a printing technique for drawing the pattern on the fabric. Regarding fibers, in the last years, Jian Feng Gu *et al.* [4] presented a highly flexible capacitor fiber having a multilayer periodic structure of dielectric and conductive polymer composite films, fabricated by drawing technique; Stephan Gorgutsa *et al.* [5] reported on soft conductive-polymer-based capacitor fibers being used to build a fully woven 2D touchpad sensor and a 1D slide sensor. Regarding transferring a pattern on the textile, Seiichi Takamatsu *et al.* [1] present a stretchable keyboard based on capacitance sensors made of PEDOT:PSS electrodes patterned on a knitted textile by using spin-coat technique; Nur Al-huda Hamdan *et al.* [6] present Grabrics, a two-dimensional textile sensor that is manipulated by grabbing a fold and moving it between fingers by using sewing techniques; Dong-Ki Kim *et al.* [7] present the design and fabrication model of a touchpad based on a contact-resistance-type force sensor fabricated by using a simple screen printing technique.

The content of the paper is organized as follows: Section II presents the working principle of pro-cap sensors; Section III describes the textile touchpad design; Section IV presents the experimental results and discussion. Finally, Section V closes the paper with conclusion and future work.

II. DESIGN AND WORKING PRINCIPLE

Touchpad developed in this work is based on projected capacitive (pro-cap) technologies [8]. Projected capacitive technologies detect touch by measuring the capacitance at each addressable electrode. When a finger approaches an electrode, it disturbs the electromagnetic field and alters the capacitance. This change in capacitance can be measured by the electronics and then converted into X,Y locations that the system can use to detect touch. There are two main types of sensing methods, self-capacitance and mutual capacitance, where each has its own advantages and disadvantages.

There are several pro-cap controllers, many of which offer both self-capacitance and mutual-capacitance types. Microchip [9] uses a hardware sensing method called Capacitive Voltage Divider (CVD), which requires only an Analog-to-Digital Converter (ADC) to preform capacitive touch sensing. Microchip has a wide range of devices which have embedded a CVD acquisition engine as MTCH6102. This device is a turnkey projected capacitive touch controller which allows designers, through of self-capacitive scanning, to quickly and easily integrate projected capacitive touch into their cost-sensitive, low-power application. Capacitive sensors are connected directly to the device and the capacitance will be continuously polled for a significant shift to occur. The shift must be appreciably higher than the noise level in the worst-case conditions.

CVD is a charge/voltage-based technique to measure relative capacitance on a pin using only the ADC module. There are several benefits to use this technique: low temperature dependence, low power supply dependence, minimal hardware requirements and low-frequency noise rejection. Theory of operation is as follows: two capacitors are charged to opposite voltages, in a first phase on the sample A and the second on the sample B (Figure 1).

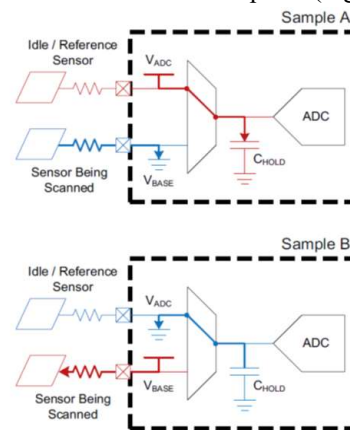

Figure 1. Theory of Operation: precharge state [9]

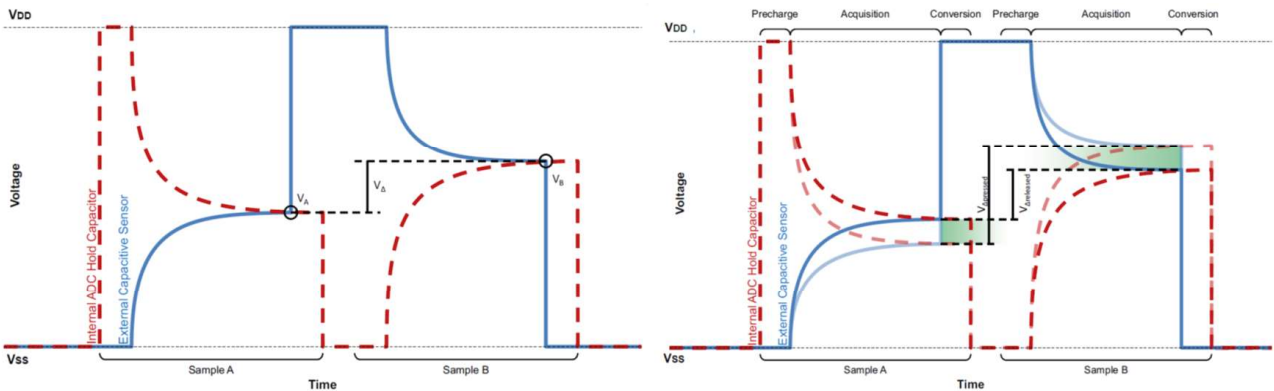

Figure 2. (Left) Differential CVD waveform; (Right) Difference between pressed and released differential values [9]

Then, the two capacitors are connected in parallel and the charges are allowed to settle. The final voltage on Hold is determined by the size of the external capacitance in relation to the size of internal capacitance. Finally, the operation is performed again, but this time the precharge voltages are reversed. The difference between the two results ($V_B - V_A$) is used as the current sensor reading (Figure 2 left). If there is an user's finger capacitance, the analysis is the same but with an additional capacitor (Figure 2 right).

A. Sensor

The capacitance of touch is dependent on sensor design, namely, on front panel thickness, electrode geometry and pitch, X-Y layer-to-layer spacing and shielding. Therefore, sensor pattern is a very important aspect of capacitive sensor design. Linearity, accuracy and resolution of touch position are greatly dependent on the sensor pattern. Commonly the design consists of a set of electrodes in row and columns to form a matrix. Several touchpad-sensor pattern designs exist, commonly referred to by names that are indicative of the shape or construction of the pattern, such as triangles, diamonds, snowflakes, streets and alleys, and telephone poles.

Diamond pattern [10]-[13] is one of the most commonly used, it consists of diamonds interconnected with a narrow neck sections (Figure 3). The sensors nodes are formed by rhombus shaped electrodes. The construction consists of two layers and each having a multitude of conductive electrodes organized parallel to each other. An individual sensors node is formed by the region between the edges of the X and Y electrodes (Figure 3).

Diamond elements are used to maximize the exposure of sensor electrodes to a touch. The distance between the electrodes is referred to as the pitch (Figure 3). The pitch determines the range of finger sizes that can reliably be

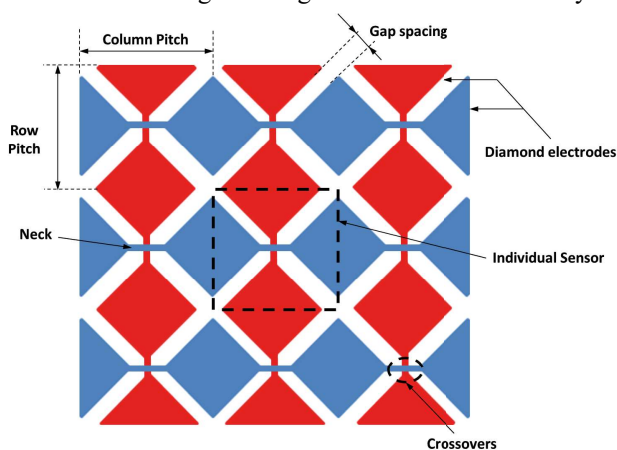

Figure 3. Diamond pattern.

detected; typical dimensions of the pitch are as minimum of 4 mm and maximum of 10 mm. The gap (Figure 3) between the X and Y electrodes determines how far a signal is projected as well as the level of noise in the measured signal. A sensor with a larger gap is able to detect a user further away but it will have more noise than a sensor with a smaller gap. A minimum of 0.1 mm and maximum of 0.5 mm have been reported.

The layers are distributed in close proximity to each other and electrically isolated from each other. The Y electrodes are arranged among rows on the top layer and the X electrodes are arranged along columns on the top layer or bottom layer (Figure 4), forming a two-dimensional array of sensors.

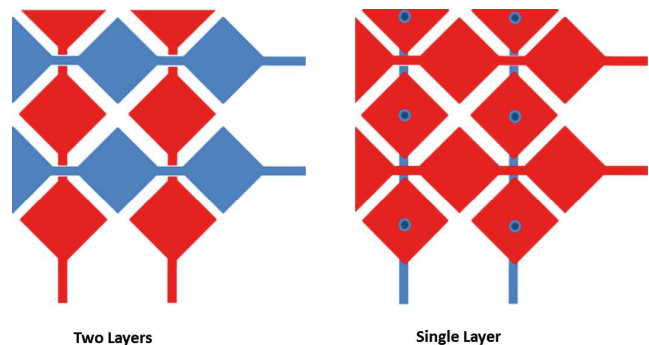

Figure 4. 2D array sensors in single layer or two layers.

In order to reduce the electromagnetic interference (EMI) to the active sensor area, a ground ring around the touchpad can be placed.

An example of diamond patten capacitive sensor can be found in the low power projected capacitive touch pad development kit (Microchip DM160219) based on MTCH6102 Microchip device. A matrix of 9 X-electrodes and 6 Y-electrodes is used (Figure 5). Dimensions of this design are:

- Pitch (Row and Column): 6.2 mm.
- Gap: 0.3 mm.

The capacity measure between electrodes is 20 pF [1 kHz] (Agilent U1731A LCR Meter).

The signal recorded on the R_{X0} line without finger touching (Figure 6 left) shows a difference of 60 mV and on the same line but touching (Figure 6 right) is 70 mV.

III. TEXTILE TOUCHPAD DESIGN

A. Screen-printed Technology

Manufacturing technology used to implement this type of sensor was based on serigraphic technology of thick film. The screen printed process consists of forcing pastes of different characteristics over a substrate through some screens using scrapers. Openings in the screen define the

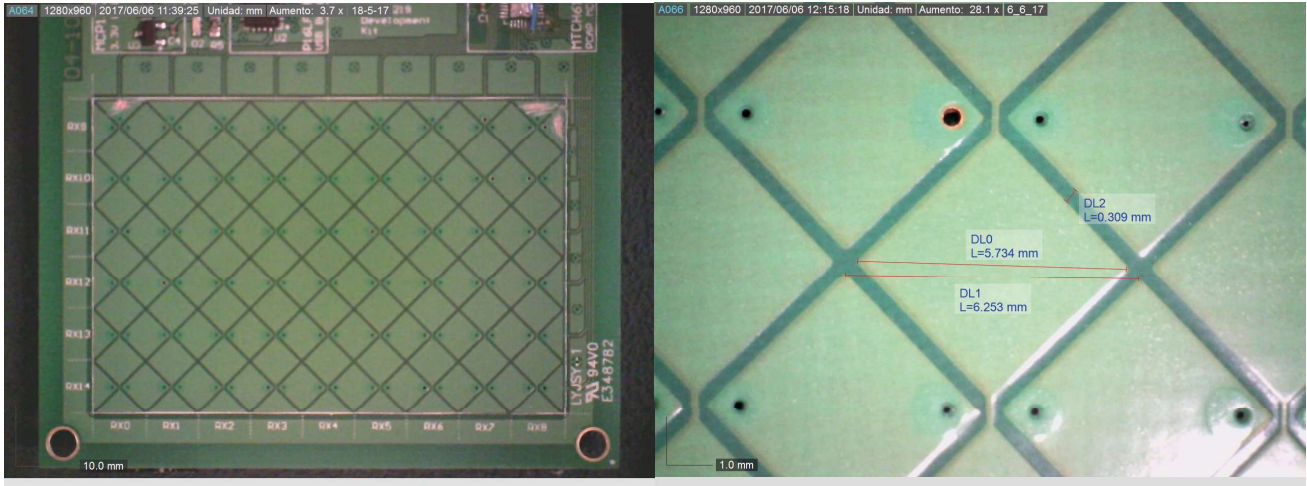

Figure 5. (Left) One layer PCB 9x6 sensor matrix; (Right) Gap and pitch size.

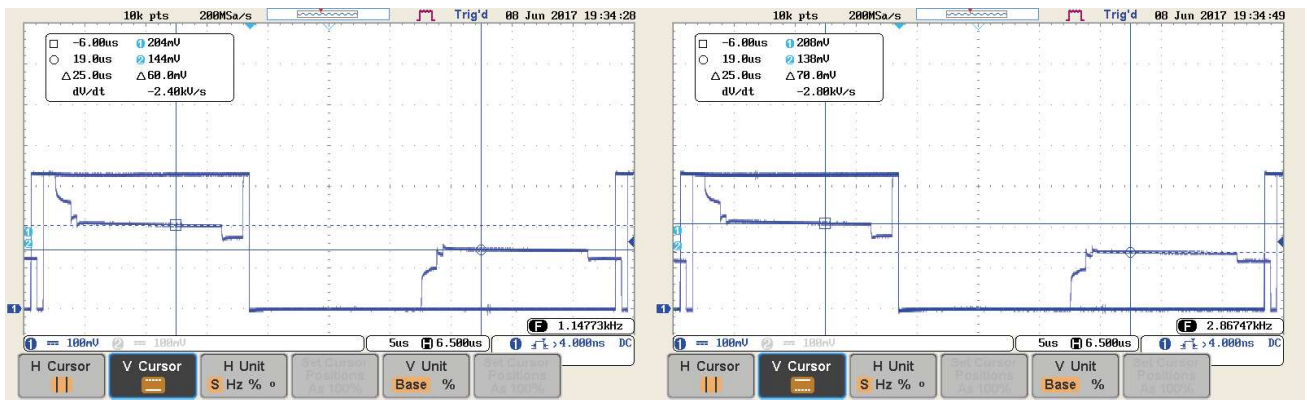

Figure 6. (Left) “released” signal ; (Right) “pressed” signal.

motif that will be printed on the substrate by serigraphy. The final thickness of the pastes can be adjusted by varying the thickness of the screens.

B. Two Layers Design [TLD]

A 9x6 sensor matrix has been designed developed with two layers of conductive tracks and one layer of dielectric. Figure 7 shows the three patterns: X layer (a), dielectric layer (b), Y layer (c) and the whole design (d).

- The main dimensions of pattern are:
- Pitch (Row and Column): 8 mm.
 - Gap: 0.4 mm.

C. One layer Design [OLD]

A 9x6 sensor matrix has been designed developed with one layer of X-Y conductive tracks and one layer of dielectric. Figure 8 shows the three patterns: Conductive shield and through hole layer (a), dielectric layer (b), X-Y layer (c) and the whole design (d).

- The main dimensions of pattern are:
- Pitch (Row and Column): 8 mm.
 - Gap: 0.5 mm.
 - Through hole diameter: 1.6 mm

D. Development

In order to build the indicated sensors matrices, three screens were made, corresponding to the three defined layers in each design. The screen for the conductors was made with a polyester material of 230 mesh PET 1500 90/230-48 (Sefar) and the screen for dielectric layer was made with a polyester material of 137 mesh PET 1500 54/137-70 (Sefar). Next, a UV film Dirasol 132 (Fujifilm) was used with a final

screen thickness of 10 μm for screen for conductors and 15 μm for screen for dielectric. The patterns were transferred to the screen by using photomaks UV light source.

The substrate used was the textile Mediatex TT ACQ 120 μm (Technohard).

The conductive paste used was the C2131014D3 Silver paste-58,85% (Gwent Group) and the dielectric paste was the D2081009D6 Polymer dielectric (Gwent Group)

Printing was carried out by using Ekra E2 XL screen-printer with a 75° shore squeegee hardness, 3.5 bar force, and 8 mm/s.

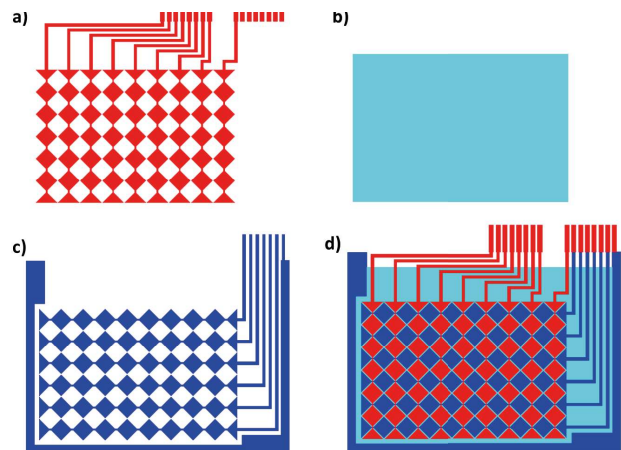

Figure 7. Two Layers Design: a) X Conductive layer ; b) Dielectric layer; c) Y Conductive layer; d) Complete Design.

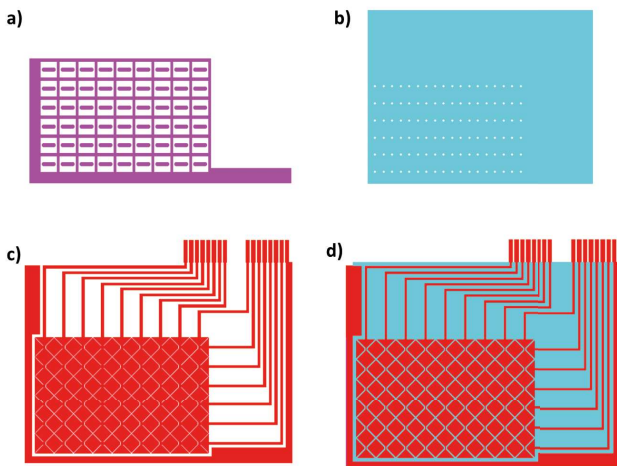

Figure 8. One Layer Design: a) Shield and through hole layer; b) Dielectric layer; c) X-Y Conductive layer; d) Complete Design

Finally, the inks were cured in an air oven at 130°C for 5 min.

To protect the surface, a new dielectric layer was added.

Short-circuits were detected between conductive layers due to the dielectric's thickness, to avoid this a total of three passes were made with dielectric ink in order to increment the dielectric's thickness.

E. Electronic System

A MTCH012 based system was designed, using PIC16LF1454 as master controller.

A Bluetooth module was used in order to make the system portable (Figure 9).

IV. RESULTS AND DISCUSSION

A. Physical Parameters

Figure 10 shows the magnification view of the two designs with the dimension. Figure 10 left shows the TLD and figure 10 right the OLD.

B. Electrical Parameters

The capacitance of the sensors has been measured by using a RCL meter to 1 kHz (Agilent U1731A). Figures 11 and 12 show the capacitance distribution in each sensor. The TDL has an average of 13 pF and OLD of 50 pF.

Regarding TLD, the signal recorded on the R_{x0} line without finger touching (Figure 13 left) shows a difference of 54 mV and on the same line but touching (Figure 13 right) is 88 mV.

Respecting OLD, the signal recorded on the R_{x0} line without finger touching shows a difference of 160 mV and on the same line but touching is 168 mV.

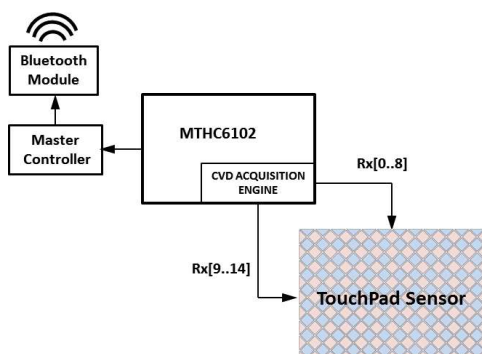

Figure 9. Electronic System Block Diagram.

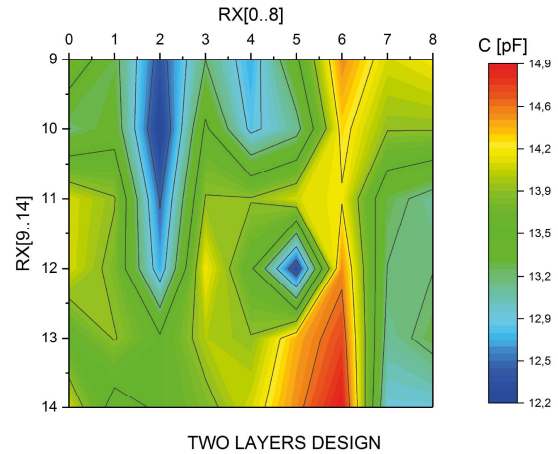

Figure 11. Capacitance distribution on TLD.

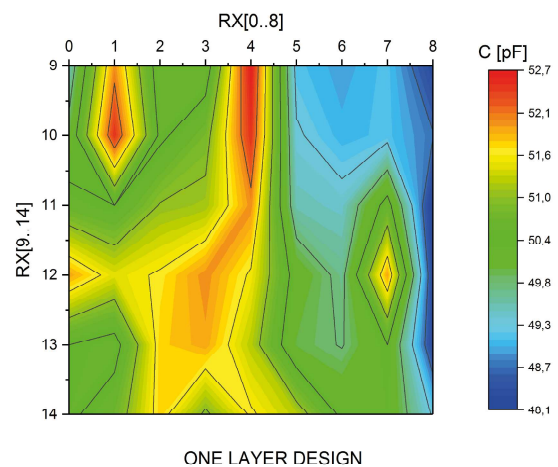

Figure 12. Capacitance distribution on OLD.

C. Operation

Both sensors were connected to the electronic system and tested with MTCH6102 utility, which allows to check all gesture detection of this device: Single Click, Click and Hold, Double Click, Right Swipe, Right Swipe and Hold, Left Swipe, Left Swipe and hold, Up Swipe, Up swipe and Hold, Down Swipe and Down Swipe and Hold. In both cases the operations were perfect and all possible gestures could be checked (Figure 14).

D. Discussion

The capacitance obtained in both cases was pretty similar to Microchip's PCB design, lower in the case of TLD. Capacitors in both cases have the same size, the difference lies in the dielectric; in TLD there is a dielectric layer between the two conductive layers whereas that in OLD there is not a dielectric layer. In spite of the technology used, the distribution of capacitance along the sensors is quite uniform. Due to its low capacitance, the differential voltage obtained with TLD is higher than that obtained with OLD even than Microchip's PCB design.

V. CONCLUSIONS AND FUTURE WORK

A touchpad based on projected capacitive (pro-cap) technologies has been developed to be used with textile substrates and using techniques of low cost and habitual in the textile industry as the screen-printing. The system works on both flat and curved surfaces, which allows it to be used in parts of clothes, such as sleeves, trouser legs or textiles



Figure 10. Magnification view of the two design: (left) Two layers design, (right) One layer design.

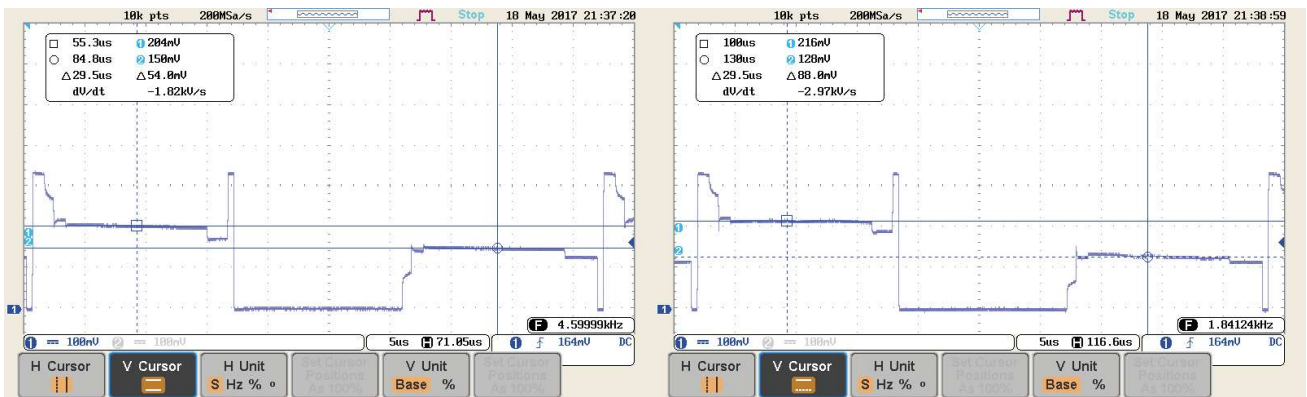

Figure 13. Two Layers Design: (Left) “released” signal ; (Right) “pressed” signal.

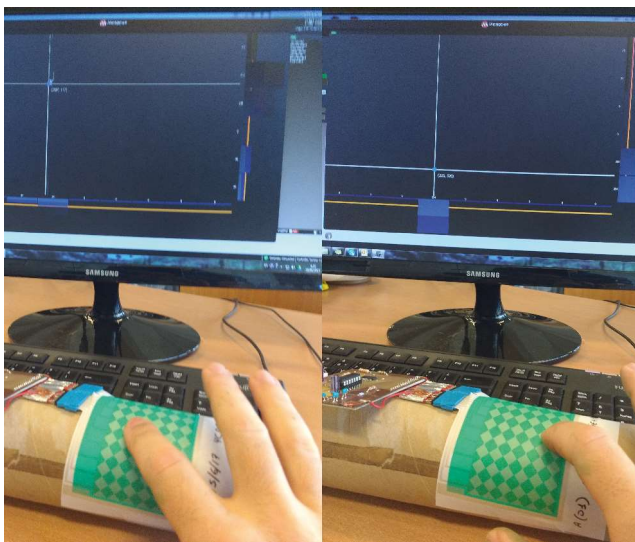

Figure 14. The function on a curved surface touching two different points.

for furniture such as sofas, armchairs, etc. When using the microchip MTCH6102 it is verified that the capacity should not be greater than hundreds of picofarad; the structure and type of dielectric have a great influence on the value of the capacity of the capacitive sensor used. An extension of this work should focus on the thickness and type of dielectric as well as the study for different types of fabrics.

ACKNOWLEDGMENT

This work was supported by Spanish Government/

FEDER funds (grant number MAT2015-64139-C4-3-R (Mineco/Feder)). The work presented is also funded by the Conselleria d’Economia Sostenible, Sectors Productius i Treball, through IVACE (Instituto Valenciano de Competitividad Empresarial) and co-funded by ERDF funding from the EU. Application no: IMAMCI/2017/1.

REFERENCES

- [1] S. Takamatsu et al., “Wearable keyboard using conducting polymer electrodes on textiles,” *Advanced Materials*, vol. 28, no. 22, pp. 4485-4488, 2015.
- [2] J. A. Fan et al., “Fractal design concepts for stretchable electronics,” *Nature communications*, vol. 5, pp. 3266, 2010.
- [3] J. A. Rogers, T. Someya and Y. Huang, “Materials and mechanics for stretchable electronics,” *Science*, vol. 327, no. 5973, pp. 1603-1607, 2010.
- [4] J. F. Gu, S. Gorgutsa, and M. Skorobogatiy, “A fully woven touchpad sensor based on soft capacitor fibers,” *arXiv preprint arXiv:1106.3881*.
- [5] S. Gorgutsa, J. F. Gu, and M. Skorobogatiy, “A woven 2D touchpad sensor and a 1D slide sensor using soft capacitor fibers,” *Smart Materials and Structures*, vol. 21, no. 1, pp. 015010, 2011.
- [6] N. A. H. Hamdan, F. Heller, C. Wacharamanotham, J. Thar, and J. Borchers, “Grabrics: A foldable two-dimensional textile input controller,” In *Proceedings of the 2016 CHI Conference Extended Abstracts on Human Factors in Computing Systems*, ACM, pp. 2497-2503, 2016.
- [7] D. K. Kim, J. H. Kim and H. J. Kwon, “A touchpad for force and location sensing,” *ETRI journal*, vol. 32, no. 5, pp. 722-728. 2010.

- [8] G. Barrett and R. Omote, "Projected-capacitive touch technology," *Information Display*, vol. 26, no. 3, pp. 16-21, 2010
- [9] Microchip Technology Inc., mTouch™ sensing solution acquisition methods capacitive voltage divider. Application note, AN1478. 2012.
- [10] Atmel. Qtouch surface design guide. Application note, AT11849.
- [11] Azoteq. A short guide on trackpad layout. Application note, AZD068. 2016
- [12] Microchip Technology Inc. FAQs-Sensor design guidelines. Application note, AD120007-001. 2012.
- [13] J. Lee, M. T. Cole, J. C. S. Lai and A. Nathan, "An analysis of electrode patterns in capacitive touch screen panels," *Journal of Display Technology*, vol. 10, no. 5, pp. 362-36, 2014.