

Unity-Warmth: Positional and Thermal Sensation Presentation System Through a Display

Suguru Sato

Faculty of Engineering
University of the Ryukyus
Okinawa, Japan
e185768@ie.u-ryukyu.ac.jp

Kagura Itokazu

Faculty of Engineering
University of the Ryukyus
Okinawa, Japan
e195709@ie.u-ryukyu.ac.jp

Yuhei Akamine

Faculty of Engineering
University of the Ryukyus
Okinawa, Japan
yuhei@ie.u-ryukyu.ac.jp

Yui Kita

H2L, Inc.
Tokyo, Japan
yui@h2l.jp

Emi Tamaki

University of the Ryukyus
H2L, Inc.
Japan
hoimei@acm.org

Abstract—In long-distance relationships, partners experience poor communication between partners because of the lacking physical existence. Current computer-mediated communication causes two types of related discomfort: "visual" and "somatosensory". This study aims to emphasize the existence (of a distant partner) by reducing these discomforts. A hypothesis about reducing these discomforts by adjusting the "visual size ratio", "consistency of position sense", and "thermal sense" was made. In the suggested system, Unity-Warmth, the communication methods are adjusted to be close to those in real life, in terms of body size, hand-contact position, and body temperature. Unity-Warmth consists of a touch panel display that can project half of someone's life-size image and a transparent heater that conveys the body's warmth. An experiment verified the effectiveness of Unity-Warmth by comparing the conventional system (Zoom Meetings) with Unity-Warmth. The results show that Unity-Warmth emphasizes five out of six types of existence: the sense that the interlocutor is "being there", the sense of participating with the interlocutor, the sense of being in the same space as the interlocutor, the realism of the interlocutor, and consistency with real-world communication experience. In the future, Unity-Warmth can be applied to communication between people who struggle to meet in person and express physical intimacy, such as "grandparents and grandchildren" and "celebrities and their fans".

Keywords—HCI; Human Interaction; Human Interface; Telepresence.

I. INTRODUCTION

The transmission of existence is important in long-distance relationships. Computer-mediated communication, such as video calls, is effective in long-distance relationships [1]–[4]. However, video calls cannot transmit much information that concerns human sensation. Therefore, partners experience poor communication because of the lacking physical existence.

The human senses are divided into three main categories: "special", "somatic", and "visceral", as shown in Figure 1. Special senses include sight, hearing, taste, smell, and equilibrium. Somatic senses are roughly divided into cutaneous and deep sensations (intrinsic sensations). These are divided by the depth of the receptors that receive information.

Cutaneous sensations are obtained through receptors near the body's surface, from the superficial layer to the dermis. There are three types of cutaneous sensations: "tactile and pressure", "warmth and cold", and "pain". Tactile and pressure sensations perceive an object's surface texture and shape when touched by a hand. Warmth and cold sensations perceive the

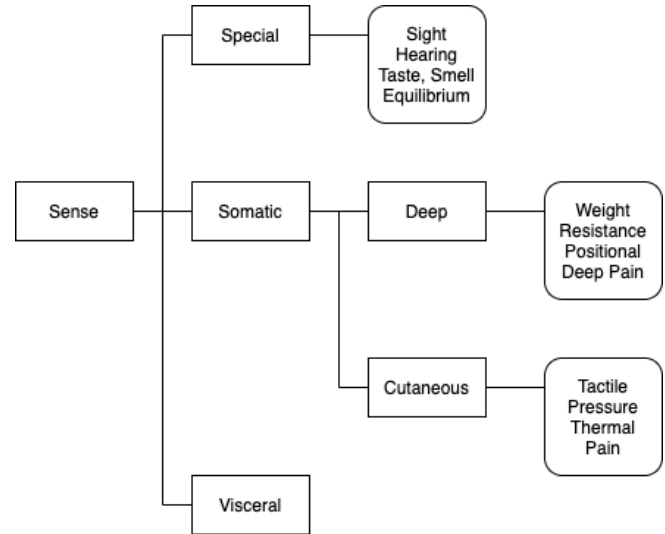

Figure 1. Types of human senses.

warmth and coldness of an object. Pain sensations perceive pain or strong warmth or coldness only on the surface layer.

Deep sensations (intrinsic sensations) are obtained by receptors intrinsic to joints, muscles, and tendons. There are three types of deep senses: "positional and motor", "resistance and weight", and "pain". Positional and motor senses perceive the position and movement of the joints and body. Resistance and weight senses perceive the stretch and tension of muscles and the position and movement of joints and the body. Pain senses perceive deep pain [5].

Computer-mediated communication is far removed from real-life communication in terms of "visual" and "somatosensory". The visual size ratio (apparent size) of face-to-face users through a computer is different from the visual size ratio of face-to-face users in the real world. This visual difference discomforts users. In addition, communication enabled by touching a display or device is good given that fingertips perceive a resistance sensation presentation. However, this generates somatosensory discomfort because of the lack of "position sensation" consistency or "thermal sensation" presentation. This lack of sensations transfer creates poor communication.

This study aims to emphasize the existence (of a distant partner) by reducing these two discomforts.

The remainder of this paper is organized as follows. Section II describes the three existence senses and current state of computer-based communication with existence. Section III describes the suggested method for reducing the discomfort of "visual" and "somatosensory" sensations in computer-mediated communication. Section IV overviews the experiment and its methods. Section V describes the results. Section VI considers the results. Finally, Section VII summarizes the results of this study and discusses future perspectives.

II. RELATED WORK

When people communicate, they perceive human existence through three types of existence: "environmental objects changed by human action", "somatosensory", and "audiovisual". The next section introduces related research divided into three types of existence.

A. Present Situation of Computer-Mediated Communication with Existence

1) Environmental Objects Changed by Human Action:

Several studies have published remote communication systems that provide users with existence of others by remotely manipulating environmental objects [6]–[13].

A study that suggested "SyncDecor", provides a virtual sense of cohabitation by synchronizing the state of remotely located household items, such as lamps and trash cans, as shown in Figure 2 [6]. This system provided a relatively strong sense of connectedness in which partners' actions in their living space impacted each other, as well as shared a weak sense of connectedness similar to conventional awareness sharing systems.

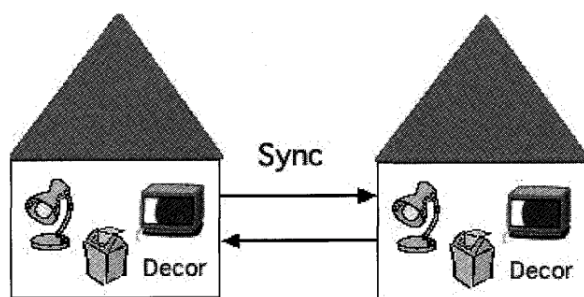

Figure 2. SyncDecor, in which environmental objects (everyday items) in remote locations are changed by human action [6]

'Tsunagari' communication aimed to foster a feeling of connection between people and maintain their social relationships [7]. A system based on this concept, called the Family Planter system, was also developed for family use.

"Lover's Cups" is a drinking-together interface that allows people to remotely share the drinking time with someone they care about [8]. Using a wireless connection, an otherwise ordinary pair of cups become a communication device, amplifying the social aspect of drinking behavior.

A study suggested a new method of communicating "awareness" between people separated by long distances to supplement existing forms of communication, such as telephone and e-mail [9]. By equipping furniture and appliances such as doors, sofas, refrigerators and televisions with sensors, a system wherein these items are connected to remote equivalents was developed, and their near-simultaneous use is communicated.

"ComSlipper" is a lightweight yet expressive sensible slipper that enhances the quality of computer-mediated relationships [10]. This system empowers wearers to create a sense of connection with others. Wearers use body gestures and tactile manipulation to feel and express emotions and availability to distant loved ones.

"Feellight" enables simple and seamless communication between distanced individuals [11].

"Connected Candles" creates awareness and connects people in long-distance relationships [12]. The system consists of a pair of candle stands, which include two candles each, one being a real candle and the other electronic. The candle stands are placed at different locations and are connected through the Internet such that lighting the real candle illuminates the electronic candle.

"Peek-A-Drawer" is a new communication device that uses furniture to support lightweight communication between people [13]. It provides virtual shared drawers that connect distanced family members.

While these systems are adequate for passive communication, they cannot actively communicate existence. They are unsuitable for partners to feel each other's existence through active communication involving contact.

2) *Existence through Somatosensory*: Numerous methods have been investigated to invoke existence by transmitting somatic sensations such as touch or temperature [14]–[21].

People prefer to use haptic (encompassed by somatosensory) communication devices, primarily with people close to them. A study on haptic modality shows that Haptics could be used for practical purposes and emotional communication, for example, in mimicking touch between partners [14].

A study that explored the importance of the touch modality on affect conveyance shows that the story accompanied by communicative touch resulted in a significant increase in the sense of connectedness with the storyteller over the speech-only condition and trended toward greater affective conveyance [15].

A study on the effectiveness of remote contact in a video meeting, where a robot hand was used to shake hands remotely, shows that two-way remote contact, between the user and device, substituting for the other person's body, are in contact at the same time on the other person's side, creating a high degree of social telepresence [16]. This study showed that creating social telepresence and giving the other person a sense of closeness is possible.

Remote hugs have also been investigated [17]. A study on the alleviating effect of virtual interpersonal touch on social judgment shows that a virtual hug reduces the negative

inferences in recalling information about a target person [18]. In a study that presented the hugging device with thermal sensation, a significant difference in social presence between those that received thermal 'hugs' and those that did not was observed [19].

As a device that provides more intimate contact, the interactive device provides a physical interface for transmitting a kiss between two remotely connected people [20], [21].

These devices can invoke existence by eliciting somatosensory sensations through contact. However, input and output location information is inconsistent with visual feedback owing to using a device with or without a display.

3) *Audiovisual Presence*: Capcom Co., Ltd. developed an adventure game for women called "Prisoner's Palma" based on the concept of "experiential love adventure through glass" [22]. In this game, a smartphone screen is used as the glass of a visiting room to realize natural physical intimacy through the display. However, the following disadvantages exist. The small screen size makes it difficult to perceive a realistic impression. The touch panel feels cold in contrast to the character's reactions, resulting in a sense of discomfort owing to the lack of "thermal sense". In a scene where the character and user hold out their hands to each other, the character's reaction does not change, whether touching the character's hand or other places, making the user feel uncomfortable because of the absent "positional sense".

A study that designed and evaluated "MyEyes", a First Person View (FPV) video streaming technology probe made with cardboard goggles and a smartphone, compared the three different views with couples to explore the effect on social presence and body ownership [23]. Distance-separated partners see each other's view on their screen, where it can overlap their own view (Overlapped), be placed above it (Horizontal), or presented in parallel such that each is seen with a different eye (Split). Couples most preferred the Overlapped View, as it provided the strongest feeling of co-presence, whereas a Horizontal View provided the greatest sense of mutual understanding. These qualitative results showed couples valued performing synchronized acts together and doing activities "in" the remote location. However, because it does not involve physical contact, it causes discomfort in the sense of touch and resistance.

B. Hypothesis

Table I compares related work for each sense.

TABLE I. COMPARISON WITH RELATED WORK

	Visual	Position Sense	Thermal Sense
SyncDecor			
Remote Handshaking	✓		✓
Toraware no Palm		✓	
Ours	✓	✓	✓

From the present situation of computer-based communication with existence, discomfort is thought to be caused by differences in "visual size ratio", "consistency of positional

sensation", and "thermal sensation" compared to the real world.

Therefore, if these differences and present "audiovisual" and "existence through somatic sensation" are eliminated, the system can reduce communication discomfort remotely.

III. METHOD

Adjust the visual size ratio such that the scale of the user's image on display is the actual size to reduce "visual" discomfort. In addition, by presenting "position sense" and "thermal sense" on the display contact surface between users, the discomfort of "position sense" consistency and "thermal sense" is reduced.

In the suggested system, the communication methods are adjusted to be close to those in real life, in terms of body size, hand-contact position, and body temperature. Our system consists of a touch panel display that can project half of a person's life-size image and a transparent heater that conveys the body's warmth, as shown in Figure 3.

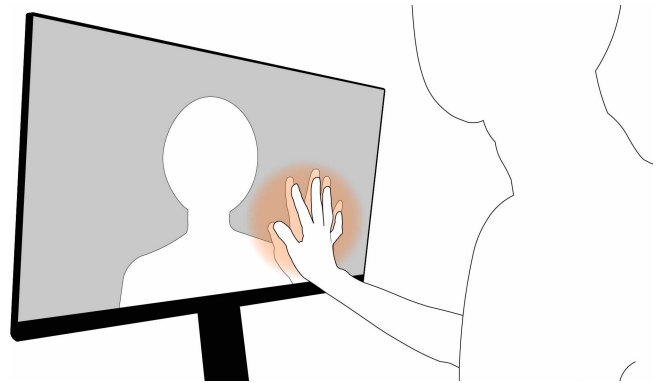

Figure 3. "Unity-Warmth" concept image.

The novelty of our system is to emphasize existence by presenting the warmth of interlocutor's body temperature while maintaining consistency between visual and position sense.

The system is named "Unity-Warmth", meaning "connecting and uniting the warmth of remote areas".

A. System Structure

Figure 4 shows the system structure of Unity-Warmth.

Unity-Warmth consists of a computer, an Arduino Pro Micro as a micro-controller, a display(27 inches) that shows the user, an ultra-wide-angle web camera (ELP USBFHD06H-BL170), and an IR touch frame to detect hand touch position. The Arduino is connected to a circuit for presenting a warm sensation. In addition, a webcam (Logitech C270n) is connected for use as the camera in the general video meeting for comparison in the experiment. It is also used as a microphone. The two computers for communication are connected by a network. The video and audio are transmitted using the web conferencing application "Zoom Meetings" (Zoom Video Communications, Inc.) [24].

By adjusting the user's size ratio using a large display, the user's size can be projected as a person's life-size image. When

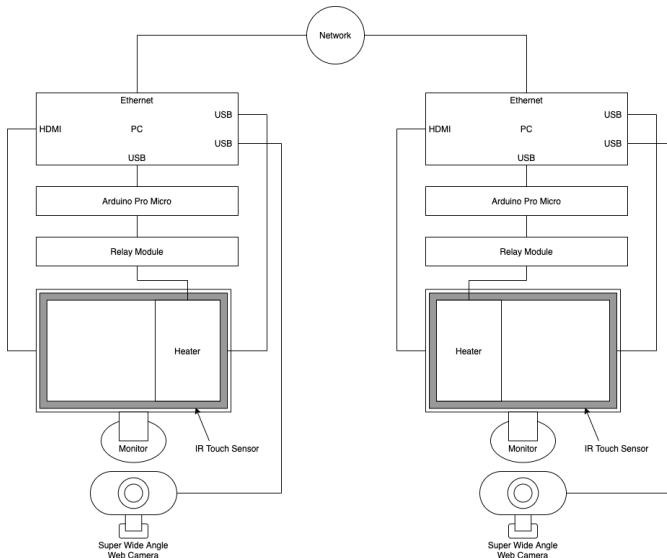

Figure 4. Unity-Warmth structure diagram.

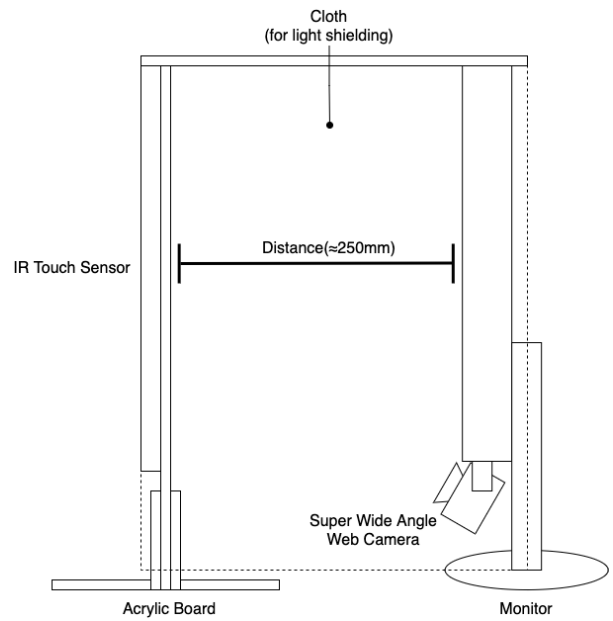

Figure 5. Side-view system schematic.

one user touches the display, the touch location is transmitted to the other device through the network. A warm sensation is presented at the corresponding point on the communications partner’s device to provide a sense of contact from a remote location.

An IR touch frame for contact detection and a heater for warmth presentation are attached to an acrylic panel as the warmth presentation unit. The heater is attached to the right edge of the screen on one device and to the left edge of the screen on the other device. Accordingly, the system can reproduce the warmth of face-to-face and hand-to-hand contact. The warmth presentation unit was placed at a 250 mm distance from the display. The black cloth covers the display and warmth presentation unit to disguise the insertion of light and display gap.

To capture both the human upper body and the hand touching the warmth presentation unit using one camera, an ultra-wide-angle camera is attached to the bottom of the display, capturing images as if looking up from below. Trapezoidal correction is performed on the captured images to make it appear as if they were shot from the front. Therefore, the system enables the capture of the hand and the user’s upper body touching the warmth presentation unit in a form close to the actual size. Figure 5 shows a side-view schematic of the system.

Figure 6 provides the developed device.

Figure 7 shows the circuit diagram.

When one user contacts the warmth presentation unit, the transmission program sends the contact state to the partner’s computer. When the receiving program receives the contact state, it sends it to the Arduino. When the Arduino receives the contact state via serial communication, it turns on the LEDs connected to the GPIO pin to indicate the operation status and outputs a voltage to the pins connected to the relay module. The output voltage from the GPIO pin is input to an 8-channel

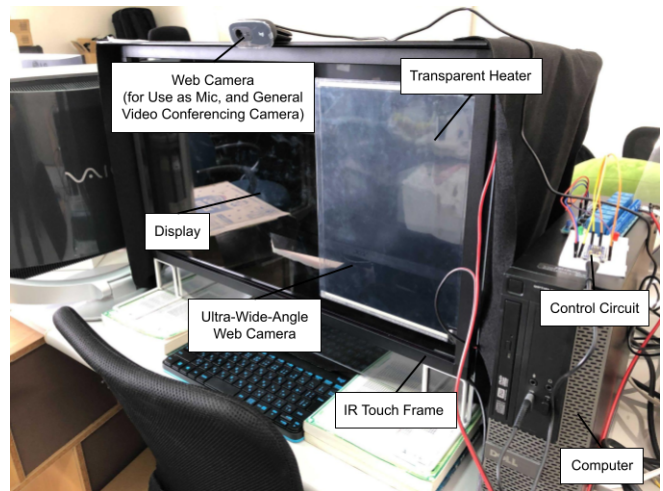

Figure 6. Picture of the developed device.

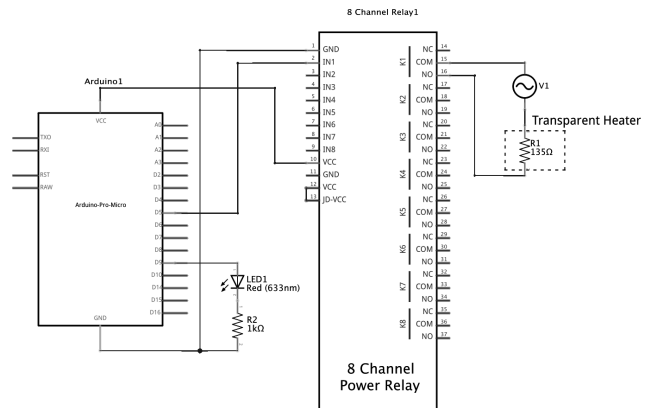

Figure 7. Circuit diagram.

relay module. A transparent heater (Mirai Tech (now: Heat Lab. Corporation) high-transparency flexible heater, A4 size) was connected to the output of the relay module to provide a warm sensation. An AC 100 V output from a household outlet is used to operate the transparent heater. Heating was controlled to activate heating when a hand touched the device and stopped when the hand is removed. Therefore, the heating of this system was not controlled by the temperature at this time.

Figure 8 shows the developed control circuit.

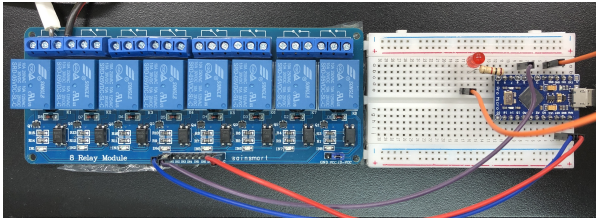

Figure 8. Control circuit.

The relay module is on the left, and the Arduino on the right. Only 1ch of the relay is used at this time.

IV. EXPERIMENT

The effectiveness of Unity-Warmth was verified by comparing a conventional computer-mediated communication method (web meeting application: Zoom Meetings) with the suggested method (Unity-Warmth). Specifically, a questionnaire survey was conducted to determine whether the user’s perception changes by changing the "visual size ratio of the user presented" and "presence of a thermal sensation through the display", and the results were then analysed.

A. Experimental Methods

The analysis was conducted from three viewpoints: "subjective evaluation", "user’s emotional change", and "existence". This experiments used a within-subjects design. The questionnaire was administered using the Visual Analog Scale (VAS). Each questionnaire item was compared by a t-test between the conventional and suggested method.

Assuming power = 0.80, effect size (delta) = 0.60, and significance level = 0.05, the optimal number of samples was $n = 23.8$. Therefore, 24 samples were collected for this experiment.

B. Tasks

To conduct a controlled experiment, the degree of attention directed to the displays and the conversations conducted through the displays should remain the same. Participants were asked to perform the following three tasks to satisfy this condition. The first task is a chat, including greetings and introductions, to build a relationship with the interlocutor and check the conversation’s spontaneity. The second task is to check the color of their partner’s eyes or the state of their partner’s fingernails to make the participants aware of their partner by paying attention to their partner’s appearance.

The third task is to compare the hand sizes to confirm the consistency difference of the "positional sense" and "thermal sense" between the conventional and suggested methods.

These three tasks help the interlocutors deepen their relationship with the first and second tasks, and then simulate skin-to-skin contact through the system to check for changes in emotion with the third task.

The tasks were the same for both the conventional and suggested methods, and the only difference is whether the touching, hand-to-hand action was performed through the suggested method during the third task.

C. Experiment Environment

A device was placed in two rooms, and participants communicate while seated in chairs.

Figure 9 shows participants participating in the experiment.



(a) Room 1

(b) Room 2

Figure 9. Experimental landscapes.

Participants sit at a certain distance such that their entire face can be seen on the display when communicating with the conventional method and as close as possible to the warmth presentation unit when communicating with the suggested method, because of the camera’s viewing angle .

D. Questionnaire

1) *Subjective Evaluation:* The questionnaire was designed to assess discomfort in computer-mediated communication subjectively. The questions were the five items listed in Table II.

TABLE II. QUESTIONNAIRE ITEMS RELATED TO SUBJECTIVE EVALUATION

Q1	The person speaking in remote may not be human (Discomfort regarding human existence)
Q2	The person speaking in remote may not be the person himself (Discomfort regarding personal existence)
Q3	The person speaking in remote may not be spending the same amount of time together (Discomfort regarding real-time progression)
Q4	The person speaking in remote may not be listening to me (Discomfort regarding attention)
Q5	The person speaking in remote may not be having me favor (Discomfort regarding favoritism)

This questionnaire aims to investigate the degree of reduction concerning the discomfort that occurs compared with real-world communication between the conventional method (web meeting) and suggested method (Unity-Warmth). Five discomforts were targeted: human existence, personal existence, real-time progression, attention, and favoritism.

2) *Emotional Change: SAM (Self-Assessment Manikin):* SAM was used to evaluate emotions [25]. SAM consists of emotional valence and arousal levels and can evaluate pleasant/displeased and excited/relaxed states on 9 levels, respectively. The participants were instructed to answer the questionnaire for emotional valence with the center as the normal state and the questionnaire for arousal level with the rightmost state as the normal state.

3) *Existence: IPQ (Igroup Presence Questionnaire):* IPQ was used to evaluate existence [26]. IPQ consists of four factors: an overall presence, presence of the virtual space, awareness of the outside world, and sense of reality. It scores the presence, immersion, and sense of presence of each content. This experiment used the six questions listed in Table III.

TABLE III. QUESTIONNAIRE ITEMS RELATED TO EXISTENCE

Q1	I had a sense that the interlocutor projected on the computer was "being there".
Q2	I did not feel that I was present beside the interlocutor
Q3	I had a sense of participating with the interlocutor
Q4	I felt present in the same space as the interlocutor
Q5	How real did the interlocutor seem to you?
Q6	How much did your experience of computer-mediated communication seem consistent with your real-world communication experiences?

Items that were unsuitable for the experiment or that were synonymous with other questions when converted into Japanese were excluded, and only items regarding existence were selected from these.

E. Participants

Participants were students between the ages of 21 and 23. Each questionnaire answered by the participant in one experiment was treated as one sample. Different combinations of participants were treated as separate samples.

V. RESULTS

The results are presented in three viewpoints: "subject evaluation", "emotional change", and "existence". Assuming power = 0.80, effect size (delta) = 0.60, and significance level = 0.05, the optimal number of samples was n = 23.8. Therefore, 24 samples were collected for this experiment.

A. Subjective Evaluation

Table IV lists the results of the t-test and average values of the subjective discomfort evaluation.

TABLE IV. T-TEST RESULTS OF SUBJECTIVE DISCOMFORT EVALUATION

Questions	Result(t-value)	Average Value	
		Web Meeting	Unity-Warmth
Q1	n.s.	85.21	88.29
Q2	n.s.	83.50	88.13
Q3	n.s.	75.58	82.25
Q4	n.s.	76.04	78.38
Q5	n.s.	31.63	31.04

Significant differences were not observed from this evaluation.

B. Emotional Change

Table V lists the results of the t-test and average values for the emotional change. Q1 is the result of the emotional valence, and Q2 of the arousal level.

TABLE V. T-TEST RESULTS OF SUBJECTIVE EMOTIONAL CHANGE EVALUATION

Questions	Result(t-value)	Average Value	
		Web Meeting	Unity-Warmth
Q1	n.s.	60.96	64.96
Q2	n.s.	49.96	59.00

Significant differences were not observed from this evaluation.

C. Existence

Table VI lists the results of the t-test and average values for existence.

TABLE VI. T-TEST RESULTS OF SUBJECTIVE EXISTENCE EVALUATION

Questions	Result(t-value)	Average Value	
		Web Meeting	Unity-Warmth
Q1	p<.001	30.29	53.83
Q2	n.s	37.83	44.67
Q3	p=.009	53.21	69.25
Q4	p=.009	48.50	64.58
Q5	p=.002	56.25	39.71
Q6	p=.005	51.42	66.88

This evaluation obtained significant differences in five out of six questions.

Figure 10 shows a radar chart of the average values of the five items for which a significant difference was obtained.

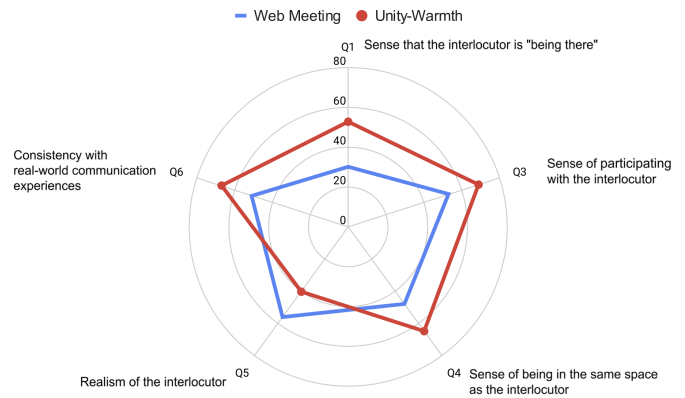

Figure 10. Radar chart of the significant differences observed from existence items.

Figure 11 shows the results of the five "existence" questions in which significant differences were obtained.

This graph is a box plot. The thick line at the center of the box plot represents the median of the data. The top of the box represents the third quartile, and the bottom of the box represents the first quartile. The upper and lower whiskers refer to the largest and smallest data points, respectively, in the range between (first quartile - 1.5*(third quartile - first quartile))

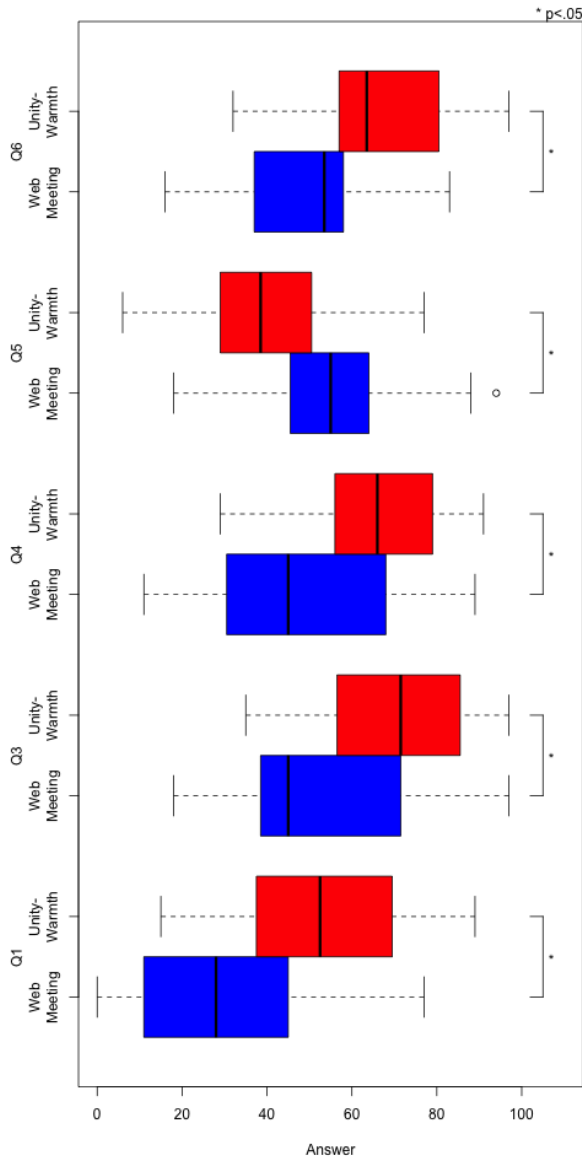

Figure 11. Box plot of the significant differences observed from existence items.

and (third quartile + 1.5*(third quartile - first quartile)). The circles represent data points that are larger or smaller than the whiskers, i.e., outliers.

VI. DISCUSSION

In this section, clarification of the reason why significant differences were obtained for "existence" but not for "subjective evaluation" and "emotional change". Each of the questions about the three viewpoints is discussed.

A. Subjective Evaluation

A paired t-test was performed on the questionnaire results of Q1 "The person speaking in remote location may not be a human (discomfort regarding the sense of human presence)".

Significant differences were not observed between the conventional method (web meeting) and suggested method (Unity-Warmth) on this question. The answers showed that many samples were obtained without significant differences between the conventional and the suggested methods. This result may be because the participants were university students, who are accustomed to video meeting, and therefore, minimally discomforted regarding the existence of the interlocutor. This may also be related to all participants knowing each other, having met face-to-face just before the experiment.

A paired t-test was performed on the questionnaire results of Q2 "The person speaking in remote may not be the person himself (Discomfort regarding personal existence)". Significant differences were not observed between the conventional method (web meeting) and suggested method (Unity-Warmth) on this question. The answer showed that many samples were obtained without significant differences between the conventional and suggested methods. This result seems to be caused by problems of participant combination, as in Q1.

A paired t-test was performed on the questionnaire result of Q3 "The person speaking in remote may not be spending the same amount of time together (Discomfort regarding real-time progression)". Significant differences were not observed between the conventional method (web meeting) and suggested method (Unity-Warmth) on this question. This result seems to be caused by problems of participant combination, as in Q1 and Q2.

A paired t-test was performed on the questionnaire result of Q4 "The person speaking in remote may not be listening to me (Discomfort regarding attention)". Significant differences were not observed between the conventional method (web meeting) and suggested method (Unity-Warmth) on this question. In this item, some answers show improvement in the suggested method (Unity-Warmth) compared to the conventional method (web meeting). However, some answers show deterioration in the suggested method compared to the conventional method. This result may be because of the unnaturalness of the line of sight and images, as Unity-Warmth uses an ultra-wide-angle web camera and performs a Trapezoidal correction.

A paired t-test was performed on the questionnaire result of Q5 "The person speaking in remote may not be having me favor (Discomfort regarding favoritism)". Significant differences were not observed between the conventional method (web meeting) and suggested method (Unity-Warmth) on this question. Many of the experiments were conducted with male participants who were not romantically involved with each other. This result may be because the participants were less likely to feel affection for each other, and thus, significant differences were not obtained.

B. Emotional Change

A paired t-test on the questionnaire results of the emotional valence (Q1) did not show significant difference between the conventional and suggested methods. Similarly, the corresponding t-test on the questionnaire results of the arousal

level (Q2) did not show significant difference between the conventional and suggested methods.

These results may indicate that the number of experiments conducted with male participants who were not romantically involved with each other was too large to obtain significant differences in emotional change. After the experiment, some male participants who were romantically attracted to women said, "I think I would be more excited and happy to use this system with a woman". This opinion suggests that the emotional change is more significant when the participants are romantic partners.

C. Existence

A paired t-test was performed on Q1 "I had a sense that the interlocutor projected on the computer was 'being there'". Significant differences were obtained between the conventional method (web meeting) and suggested method (Unity-Warmth) on this question. The average VAS value of the suggested method (Unity-Warmth) was 53.83 mm, and that of the conventional method (web meeting) was 30.29 mm. In this question, a VAS value of 0 mm means "not at all", and 100 mm means "very much". Therefore, the suggested method (Unity-Warmth) provides "the sense that the interlocutor is 'being there'" more significantly than the conventional method (web meeting).

A paired t-test was performed on Q2 "I did not feel that I was present next to the interlocutor". Significant differences were not obtained between the conventional method (web meeting) and suggested method (Unity-Warmth) on this question.

A paired t-test was performed on Q3 "I had a sense of acting with the interlocutor". Significant differences were obtained between the conventional method (web meeting) and suggested method (Unity-Warmth) on this question. The average VAS value of the suggested method (Unity-Warmth) was 69.25 mm, and that of the conventional method (web meeting) was 53.21 mm. In this question, a VAS value of 0 mm means "fully disagree", and 100 mm means "fully agree". Therefore, the suggested method (Unity-Warmth) provides "the sense of participating with the interlocutor" more significantly than the conventional method (web meeting).

A paired t-test was performed on Q4 "I felt present in the same space with the interlocutor". Significant differences were obtained between the conventional method (web meeting) and suggested method (Unity-Warmth) on this question. The average VAS value of the suggested method (Unity-Warmth) was 64.58 mm, and that of the conventional method (web meeting) was 48.50 mm. In this question, a VAS value of 0 mm means "fully disagree", and 100 mm means "fully agree". Therefore, the suggested method (Unity-Warmth) provides "the sense of being in the same space as the interlocutor" more significantly than the conventional method (web meeting).

A paired t-test was performed on Q5 "How real did the interlocutor seem to you?". Significant differences were obtained between the conventional method (web meeting) and suggested method (Unity-Warmth) on this question. The average VAS value of the suggested method (Unity-Warmth) was 39.71 mm,

and that of the conventional method (web meeting) was 56.25 mm. In this question, a VAS value of 0 mm means "not real at all", and 100 mm means "completely real". Therefore, the suggested method (Unity-Warmth) provides "the realism of the interlocutor" more significantly than the conventional method (web meeting).

A paired t-test was performed on Q6 "How much did your experience of computer-mediated communication seem consistent with your real-world communication experience?". Significant differences were obtained between the conventional method (web meeting) and suggested method (Unity-Warmth) on this question. The average VAS value of the suggested method (Unity-Warmth) was 66.88 mm, and that of the conventional method (web meeting) was 51.42 mm. In this question, a VAS value of 0 mm means "not consistent", and 100 mm means "very consistent". Therefore, the suggested method (Unity-Warmth) gives "consistency with real-world communication experience" more significantly than the conventional method (web meeting).

Significant differences were obtained for five of the six items, indicating an improved existence. That is, this system can provide communication with an existence significantly more effective than web meeting.

Another reason for the lack of significant differences in Q2 may have been the difficulty understanding the questionnaire. For the question "I did not feel that I was present beside the interlocutor", a VAS value of 0 mm meant "not at all", and 100 mm meant "very much". Therefore, several participants asked, "Which is 'I felt that I was present next to the interlocutor'?" about the interpretation of the question. It may have been necessary to explain the interpretation of the questions and response scales to all participants in advance.

VII. CONCLUSION AND FUTURE WORK

This study shows that Unity-Warmth provide better communication with existence even in remote areas. In the future, Unity-Warmth can be applied to communication between people who struggle to meet in person and express physical intimacy, such as "grandparents and grandchildren" and "celebrities and their fans". The following section introduces the conclusion and future works in detail.

A. Conclusion

This study aims to emphasize the existence (of the distant partner) by reducing two discomforts "visual" and "somatosensory" of computer-mediated communication.

In the suggested system, Unity-Warmth, the communication methods are adjusted to be close to those in real life, in terms of body size, hand-contact position, and body temperature. Unity-Warmth consists of a touch panel display that can project half of a person's life-size image and a transparent heater that conveys the body's warmth.

An experiment verified the effectiveness of Unity-Warmth by comparing the conventional system (Zoom Meetings) with Unity-Warmth. Consequently, significant differences were not obtained for "subjective evaluation" and "emotional change".

However, the "existence" questionnaire obtained significant differences in five of the six questions. The suggested method (Unity-Warmth) was more effective than the conventional method (web meeting) in terms of the sense that the interlocutor is "being there", sense of participating with the interlocutor, sense of being in the same space as the interlocutor, realism of the interlocutor, and consistency with real-world communication experience. That is the suggested method (Unity-Warmth) can provide better "communication with existence even in remote areas", which is the goal of this research, compared with the conventional method (web meeting).

However, because significant differences were not identified in the questionnaires of the "subjective evaluation of discomfort" and "emotional change", questions remain concerning the discomfort changes of "visual" and "somatosensory". A possible reason for the absent significant differences in this survey can be the combination of participants. In addition, the suggested method (Unity-Warmth) requires some visual improvements, such as "video distortion and line of sight improvement", "internal reflection reduction", and "quality of transmitted video and audio". Addressing these improvements is expected to provide existence further.

B. Future Work

The participants in this experiment were only niche students who knew each other and were not romantically involved with each other. The results shows that there is no significant difference was in the subjective evaluation of discomfort.

In the future, we would like to conduct experiments with a wider range of age groups and participants with romantic or friendship relationships and compare the results.

Investigating whether the suggested method helps resolve the sense of discomfort in long-distance communication is expected.

Conducting the survey again by collecting a sample that considers whether the respondents are in romantic interest involved is expected.

Furthermore, Unity-Warmth will be tested with couples in long-distance relationships, which is the long-term background of this study to investigate the degree to which the suggested system enriches long-distance communication. Moreover, Unity-Warmth can be applied to communication between people who struggle meeting directly and expressing physical intimacy, such as "grandparents and grandchildren" and "celebrities and their fans".

In evaluating communication involving remote contact, the 9-item questionnaire exists to measure the "Social Disfor-dance" of Mediated Social Touch, with three scales that focus on Social Discomfort, Communicational Expressiveness, and Need for Additional Consideration [27]. Conducting more suitable questionnaires for evaluating communication involving remote contact is expected.

The following four points can be identified as areas of improvement for suggested device. First, the images captured by the ultra-wide-angle camera are distorted. Second, adjust the camera position to make the line of sight natural. Third,

the content displayed on display is reflected in the captured image owing to the internal reflection of the acrylic plate of the warm sensation unit placed in front of the display. Fourth, is the quality of the transmitted video and audio. These improvements will produce better results. In addition, the heating of the present device was not controlled by the temperature. Therefore, verifying the difference in effect depending on the temperature provided by the device is expected.

REFERENCES

- [1] C. Neustaedter and S. Greenberg, "Intimacy in long-distance relationships over video chat," *Proceedings of the SIGCHI Conference on Human Factors in Computing Systems*, pp. 753–762, Association for Computing Machinery, 2012.
- [2] A. P. N. Aguila, "Living long-distance relationships through computer-mediated communication," *Social Science Diliman*, vol. 5, pp. 83–106, 2011.
- [3] S. Greenberg and C. Neustaedter, "Shared living, experiences, and intimacy over video chat in long distance relationships," *Connecting Families: The Impact of New Communication Technologies on Domestic Life*, pp. 37–53, Springer London, 2013.
- [4] L. Kusisto, "The impact of video chatting on idealization and disillusionment for long distance dating couples," *Theses and Dissertations—Family Sciences*, vol. 31, University of Kentucky Libraries, 2015.
- [5] E. Tamaki, "[Method of presenting somatosensory stimuli in a VR environment] VR kankyou ni okeru taiseikannkaku sigeiki no teizi houhou (in japanese)," *Journal of the Society of Biomechanisms*, vol. 43, no. 1, pp. 3–9, 2019.
- [6] H. Tsujita, K. Tsukada, and I. Sii, "Syncdecor: Communication appliances for couples separated by distance," *2008 The Second International Conference on Mobile Ubiquitous Computing, Systems, Services and Technologies*, pp. 279–286, 2008.
- [7] Y. Itoh, A. Miyajima, and T. Watanabe, "'tsunagari' communication: fostering a feeling of connection between family members," *CHI '02 Extended Abstracts on Human Factors in Computing Systems*, pp. 810–811, 2002.
- [8] H. Chung, C. J. Lee, and T. Selker, "Lover's cups: Drinking interfaces as new communication channels," *CHI '06 Extended Abstracts on Human Factors in Computing Systems*, CHI EA '06, pp. 375–380, Association for Computing Machinery, 2006.
- [9] H. Tsujita, K. Tsukada, and I. Sii, "Inphase: Evaluation of a communication system focused on "happy coincidences" of daily behaviors," *Proceedings of the SIGCHI Conference on Human Factors in Computing Systems*, CHI '10, pp. 2481–2490, Association for Computing Machinery, 2010.
- [10] C. Chen, J. Forlizzi, and P. L. Jennings, "Comslipper: An expressive design to support awareness and availability," *CHI '06 Extended Abstracts on Human Factors in Computing Systems*, CHI EA '06, pp. 369–374, Association for Computing Machinery, 2006.
- [11] K. Suzuki and S. Hashimoto, "Feellight: A communication device for distant nonverbal exchange," *Proceedings of the ACM SIGMM 2004 Workshop on Effective Telepresence - ETP 2004*, pp. 40–44, 2004.
- [12] J. Häkkinen, H. Li, S. Koskinen, and A. Colley, "Connected candles as peripheral emotional user interface," *Proceedings of the 17th International Conference on Mobile and Ubiquitous Multimedia*, pp. 327–333, Association for Computing Machinery, 2018.
- [13] I. Sii, J. H. Rowan, and E. D. Mynatt, "Peek-a-drawer: Communication by furniture," *CHI '02 Extended Abstracts on Human Factors in Computing Systems*, pp. 582–583, Association for Computing Machinery, 2002.
- [14] K. Suhonen, K. Väänänen, and K. Mäkelä, "User experiences and expectations of vibrotactile, thermal and squeeze feedback in interpersonal communication," *Proceedings of the 26th Annual BCS Interaction Specialist Group Conference on People and Computers*, pp. 205–214, BCS Learning & Development Ltd., 2012.
- [15] R. Wang, F. K. H. Quek, D. G. Tatar, J. K. S. Teh, and A. D. Cheok, "Keep in touch: Channel, expectation and experience," *Proceedings of the SIGCHI Conference on Human Factors in Computing Systems*, pp. 139–148, Association for Computing Machinery, 2012.

- [16] H. Nakanishi, K. Tanaka, and Y. Wada, "Remote handshaking: Touch enhances video-mediated social telepresence," *Proceedings of the SIGCHI Conference on Human Factors in Computing Systems*, CHI '14, (New York, NY, USA), pp. 2143–2152, Association for Computing Machinery, 2014.
- [17] F. Mueller, F. Vetere, M. R. Gibbs, J. Kjeldskov, S. Pedell, and S. Howard, "Hug over a distance," *CHI '05 Extended Abstracts on Human Factors in Computing Systems*, pp. 1673–1676, Association for Computing Machinery, 2005.
- [18] J. Nakanishi, H. Sumioka, and H. Ishiguro, "Virtual hug induces modulated impression on hearsay information," *Proceedings of the 6th International Conference on Human-Agent Interaction*, pp. 199–204, Association for Computing Machinery, 2018.
- [19] D. Gooch and L. A. Watts, "Communicating social presence through thermal hugs," *Proc. Ubicomp 2010 SISSE Workshop*, pp. 11–20, 2010.
- [20] H. A. Samani, R. Parsani, L. T. Rodriguez, E. Saadatian, K. H. Dissanayake, and A. D. Cheok, "Kissenger: Design of a kiss transmission device," *Proceedings of the Designing Interactive Systems Conference*, pp. 48–57, Association for Computing Machinery, 2012.
- [21] H. A. Samani, J. K. S. Teh, E. Saadatian, and R. Nakatsu, "Xoxo: Haptic interface for mediated intimacy," *2013 International Symposium on Next-Generation Electronics*, pp. 256–259, 2013.
- [22] "CAPCOM: Toraware no palm official site." <https://www.capcom.co.jp/palm/>. [retrieved: May, 2022].
- [23] R. Pan, S. Singhal, B. E. Riecke, E. S. Cramer, and C. Neustaedter, "'myeyes': The design and evaluation of first person view video streaming for long-distance couples," *Proceedings of the 2017 Conference on Designing Interactive Systems*, pp. 135–146, Association for Computing Machinery, 2017.
- [24] "Zoom meetings | zoom." <https://explore.zoom.us/en/products/meetings/>. [retrieved: May, 2022].
- [25] M. M. Bradley and P. J. Lang, "Measuring emotion: the self-assessment manikin and the semantic differential," *Journal of behavior therapy and experimental psychiatry*, vol. 25, no. 1, pp. 49–59, 1994.
- [26] "igroup presence questionnaire (IPQ) overview | igroup.org – project consortium." <http://www.igroup.org/pq/ipq/index.php>. [retrieved: May, 2022].
- [27] K. Mejia and S. Yarosh, "A nine-item questionnaire for measuring the social disfordance of mediated social touch technologies," *Proc. ACM Hum.-Comput. Interact.*, vol. 1, no. CSCW, pp. 1–17, 2017.