

# Reduced Hamiltonian Technique for Gate Design in Strongly Coupled Quantum Systems

Preethika Kumar, Steven R. Skinner and, Sahar Daraeizadeh

Department of Electrical Engineering and Computer Science

Wichita State University

Wichita, USA

[preethika.kumar@wichita.edu](mailto:preethika.kumar@wichita.edu), [steven.skinner@wichita.edu](mailto:steven.skinner@wichita.edu), [sxdaraeizadeh@wichita.edu](mailto:sxdaraeizadeh@wichita.edu)

**Abstract**—We introduce a new reduced-Hamiltonian scheme for realizing universal quantum computing in strongly coupled multi-qubit systems. This technique provides analytic solutions to the time evolution of the system, so that experimentalists can easily choose system parameters to realize desired quantum gates. We show how to implement arbitrary controlled-unitary operations in a one-dimensional nearest-neighbor architecture by deriving system parameters to achieve these operations. The key feature of the scheme is that all gate operations are realized by varying only a single control parameter, which greatly reduces the circuit complexity. Furthermore, we do not require the ability to tune couplings during a computation. We also show how the scheme can be extended to realize a controlled-unitary operation, involving  $N$  control qubits and one target qubit, in a single pulse.

**Keywords**—quantum; nearest-neighbor; gates; controlled-unitary; coupling; Hamiltonian

## I. INTRODUCTION

A quantum computer comprises several qubits interacting with each other. Most schemes for implementing a quantum computer in different physical quantum systems are nearest-neighbor (NN), which comprise one- and two-dimensional arrays of qubits where each qubit interacts only with the qubits adjacent to it [1-26]. In these systems, when performing single- and multi-qubit gate operations, if the interactions are not turned off, the evolution of the qubit on which the gate operation is performed is affected by the other qubits it is coupled to. As a result, a number of methods for isolating a qubit from its neighbors, by shutting off the coupling, have been devised in various quantum systems [12-19, 27-34]. For instance, in phosphorus doped silicon systems, a method is employed of applying voltage biases to surface control electrodes, in order to vary the exchange coupling between neighboring donor atoms [27]. In GaAs/AlGaAs electron spin quantum dots, the strength of the exchange interaction, which depends on the overlap of the respective electron wavefunctions, is varied by changing the voltage applied to the gate controlling the tunnel barrier between the two dots [17]. In charge qubits, nearest neighbors are coupled via loop-shaped electrodes with Josephson junctions (JJs) at the loop intersections, where the bias currents through the coupling JJs serve as interaction control knobs [19]. In coupled quantum dot molecules, the coupling is switched off by grounding metal film electrodes between two qubits which turns off the Coulomb interaction between qubits [26]. While all these

methods of switching couplings facilitate multi-qubit operations, there are disadvantages in using tunable coupling. The ability to switch couplings usually involves performing fast changes in the qubit parameters or using additional circuit elements, both of which increase the complexity of the experimental set-up and open the system to noise.

A desirable alternative to the ability to switch couplings is to devise methods for performing computations with always-on interactions, wherein the ability to tune couplings is no longer required. To this end, a number of schemes have been proposed [33-41]. In [35], Zhou *et al.* devised a two-dimensional architectural scheme for universal and scalable quantum computation where the coupling between encoded qubits are effectively turned on and off by computing in and out of carefully designed interaction free subspaces analogous to decoherence free subspaces. In [36], Benjamin *et al.* showed how to perform computations along a one-dimensional array by tuning the Zeeman transition energies of individual qubits. Recently, schemes employing global control have been proposed [37, 38] and implemented in optical systems [39] and antiferromagnetic spin rings [40]. While each of these methods allows us to perform computations without having to switch couplings, each method has its own disadvantages. From a practical standpoint, the scheme in [35] is complex in terms of the two-dimensional physical arrangement of qubits, initialization, and the steps involved in generating gates. The scheme in [36] requires placing intervening qubits in definite classical states in order to negate the residual Ising interaction, thereby increasing the computational overhead. The scheme in [37], which uses translation-invariant operations to perform universal quantum computations, has a constant spatial and linear temporal overhead.

In this paper, we present a new reduced-Hamiltonian scheme for implementing universal quantum computing in strongly coupled systems. The technique works in both NN and non-NN architectures, and without having to shut off the coupling between qubits. In systems with switchable interactions, the couplings can be tuned to desired values at the start of a computation. These couplings, once set, will not be varied during the computation. The main advantage of our scheme is that it is simple and efficient, because only a single control parameter is pulsed high for all gate operations. The number of pulses for a gate operation varies depending on the number of qubits involved in the gate operation. For instance, in a one-dimensional Linear NN (LNN) array, a three-qubit Toffoli gate requires one pulse, a two-qubit CNOT gate

requires two pulses, and a single qubit gate requires four pulses. In this work, we first describe how to implement gate operations in a one-dimensional LNN architecture. We include the effects of finite rise and fall times due to non-ideal pulses on gate operations. Next, we extend the scheme to show how a controlled-unitary operation with multiple controls and a single target qubit can be realized in a single pulse. Unlike previous schemes [35, 36], our method does not require encoding physical qubits into logical qubits. Neither does it require separating qubit-bearing spins by passive “barrier” spins [37], thereby, significantly minimizing the computational overhead.

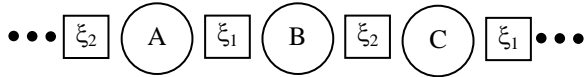

Figure 1. Linear nearest-neighbor array of qubits where each qubit is only coupled to the two qubits adjacent to it. Here, the circles represent individual qubits and the squares represent the couplings between qubits. There are two coupling constants,  $\xi_1$  and  $\xi_2$ , which alternate along the length of the chain.

The paper is organized as follows. In Section II, we describe how to implement gate operations in an LNN architecture. We show how to reduce the Hamiltonian of a three-qubit system, and then calculate parameters to implement gate operations. We assume a diagonal-type Ising interaction between qubits and then extend the scheme to Heisenberg interactions. In Section III, we present the conclusions.

## II. GATE OPERATIONS IN LNN ARCHITECTURES

Figure 1 shows an LNN architecture, where each qubit is represented as a circle, and the couplings between qubits are represented by squares. Each qubit is coupled to every qubit through an Ising-type interaction, which is diagonal in the interaction basis. Such an Ising type coupling between qubits is commonly seen in proposals for superconducting Josephson junction qubits [34, 35], and also arises as one limit of dipole-dipole or J-coupling systems [34, 36]. In our design, we assume only two coupling constants,  $\xi_1$  and  $\xi_2$ , which alternate along the length of the architecture. The design can be implemented in systems with and without tunable couplings. For instance, in charge qubits with fixed couplings [42], the coupling capacitances between adjacent boxes can be fabricated to alternate along a line of qubits. If the coupling is tunable, as in [19] where nearest-neighbor charge qubits are coupled through loop-shaped electrodes with JJs at the loop intersections, the bias currents through alternate JJs can be fixed such that they alternate along the length of the chain. These currents, once set, will not be varied during the computation.

Consider only three adjacent qubits along the line – qubits A, B and C in Fig. 1. The Hamiltonian describing the evolution of this system is an  $8 \times 8$  matrix:

$$\mathbf{H} = \sum_{i=A,B,C} \left( \Delta \sigma_{x_i} + k \sigma_{y_i} + \varepsilon_i \sigma_{z_i} \right) + \xi_1 \sigma_{z_A} \sigma_{z_B} + \xi_2 \sigma_{z_B} \sigma_{z_C} \quad (1)$$

Here,  $\varepsilon_i$  is the bias acting on individual qubits, which will be the control parameter in our system. We assume the qubits to be identical in design, in that the tunneling parameters ( $\Delta$  and  $k$ ) are identical. The bias parameter controls the tendency of the qubit to remain in its state. The tunneling parameter controls the tendency of the qubit to switch between the two basis states. We will also choose the magnitude of the coupling to be much larger than the tunneling, i.e.,  $\xi_1 \gg \Delta$  (or  $k$ ) and  $\xi_2 \gg \Delta$ . Two different values of the coupling are required, so that qubit B can distinguish between qubits A and C.

Suppose that, initially, the bias equal zero for all qubits. Next, the bias on qubit, B, is raised to some value of  $\varepsilon_B$ . As a result, Eq. (1) becomes:

$$\mathbf{H} = \Delta \left( \sigma_{x_A} + \sigma_{x_B} + \sigma_{x_C} \right) + k \left( \sigma_{y_A} + \sigma_{y_B} + \sigma_{y_C} \right) + \varepsilon_B \sigma_{z_B} + \xi_1 \sigma_{z_A} \sigma_{z_B} + \xi_2 \sigma_{z_B} \sigma_{z_C} \quad (2)$$

Since  $\xi_1 \gg \Delta$  and  $\xi_2 \gg \Delta$ , the expectation values of the  $\sigma_{z_A}$  and  $\sigma_{z_C}$  operators are either +1 or -1, depending on whether qubits A and C are in the  $|0\rangle$  or  $|1\rangle$  states, respectively. Therefore, we can write four  $2 \times 2$  reduced Hamiltonians for qubit B in the subspaces where qubits A and C are in the  $|00\rangle$ ,  $|01\rangle$ ,  $|10\rangle$  and  $|11\rangle$  states, respectively:

$$\mathbf{H}_B^{(00)} = \Delta \sigma_x + k \sigma_y + (\varepsilon_B + \xi_1 + \xi_2) \sigma_z, \quad (3)$$

$$\mathbf{H}_B^{(01)} = \Delta \sigma_x + k \sigma_y + (\varepsilon_B + \xi_1 - \xi_2) \sigma_z, \quad (4)$$

$$\mathbf{H}_B^{(10)} = \Delta \sigma_x + k \sigma_y + (\varepsilon_B - \xi_1 + \xi_2) \sigma_z, \quad (5)$$

$$\mathbf{H}_B^{(11)} = \Delta \sigma_x + k \sigma_y + (\varepsilon_B - \xi_1 - \xi_2) \sigma_z. \quad (6)$$

Observe that if  $\varepsilon_B \ll \xi_1$  ( $\xi_2$ ), qubit B undergoes Z rotations in each subspace. However, since the couplings directly add to or subtract from the parameter  $\varepsilon_B$  in each subspace,  $\varepsilon_B$  can be so chosen as to cancel or minimize the effects of the large coupling. As a result, unitary gate operations other than Z rotations can be realized. We will use this principle to realize different controlled-unitary and single-qubit operations in the system of 3 qubits.

A controlled-unitary operation,  $C^N(\mathbf{U})$ , comprises N control qubits and one target qubit [43]. The desired unitary operation,  $\mathbf{U}$ , is performed on the target qubit when the control qubits are in a given state, usually when all the controls are in the  $|1\rangle$  state. Suppose we want to perform a controlled-unitary operation,  $C^2(\mathbf{U})$ , on qubits A, B and C, with qubits A and C as controls and qubit B as the target. A general single-qubit unitary operation can be written as:

$$\mathbf{U} = \begin{pmatrix} \exp\left(-i\left(\frac{\beta+\delta}{2}\right)\right)\cos\left(\frac{\gamma}{2}\right) & -\exp\left(-i\left(\frac{\beta-\delta}{2}\right)\right)\sin\left(\frac{\gamma}{2}\right) \\ \exp\left(+i\left(\frac{\beta-\delta}{2}\right)\right)\sin\left(\frac{\gamma}{2}\right) & \exp\left(+i\left(\frac{\beta+\delta}{2}\right)\right)\cos\left(\frac{\gamma}{2}\right) \end{pmatrix}, \quad (7)$$

where  $\mathbf{U}$  is a  $2 \times 2$  unitary matrix belonging to  $\mathbf{SU}(2)$  [43], which is the set of  $2 \times 2$  unitary matrices with unit determinant. The values of  $\beta$ ,  $\delta$  and  $\gamma$  can be chosen to realize the desired unitary transformation. Suppose we desire that only in the subspace where the control qubits are in the  $|11\rangle$  state, the unitary operation given by Eq. (7) be performed on the target qubit B. This implies that the unitary matrices generated by each of the Hamiltonians given by Eqs. (3) through (5) be  $2 \times 2$  identity matrices. Likewise, the unitary matrix generated by the Hamiltonian given by Eq. (6) must be  $\mathbf{U}$ . Since  $\xi_1$  ( $\xi_2$ )  $\gg \Delta$ , we require that  $(\varepsilon_B - \xi_1 - \xi_2)$  be of the order of  $\Delta$ , i.e.,

$$\varepsilon_B - \xi_1 - \xi_2 = m\Delta, \quad (8)$$

where  $0 \leq m \leq 1$ . Note that  $m \gg 1$  will correspond to the condition  $\varepsilon_B \gg \Delta$ , in which case, the target undergoes Z rotations. Using Eq. (8) in Eqs. (3) through (6), we have,

$$\begin{aligned} \mathbf{H}_B^{(00)} &= \Delta\sigma_x + k\sigma_y + (m\Delta + 2(\xi_1 + \xi_2))\sigma_z, \\ &\approx 2(\xi_1 + \xi_2)\sigma_z \end{aligned} \quad (9)$$

$$\mathbf{H}_B^{(01)} = \Delta\sigma_x + k\sigma_y + (m\Delta + 2\xi_1)\sigma_z \approx 2\xi_1\sigma_z, \quad (10)$$

$$\mathbf{H}_B^{(10)} = \Delta\sigma_x + k\sigma_y + (m\Delta + 2\xi_2)\sigma_z \approx 2\xi_2\sigma_z, \quad (11)$$

$$\mathbf{H}_B^{(11)} = \Delta\sigma_x + k\sigma_y + m\Delta\sigma_z. \quad (12)$$

We can see that under the first three Hamiltonians, Eqs. (9) through (11), target qubit B undergoes Z rotations. However, the values of  $\xi_1$  and  $\xi_2$  can be so chosen that within the time step of the gate operation, the Z rotations correspond to integer multiples of  $2\pi$ , wherein the unitary matrices generated are identity operations. Integrating the Hamiltonian given by Eq. (12), we obtain the following unitary matrix:

$$\begin{pmatrix} \cos(2\pi ft) - i\frac{m\Delta}{f}\sin(2\pi ft) & \frac{k-i\Delta}{f}\sin(2\pi ft) \\ \frac{-k-i\Delta}{f}\sin(2\pi ft) & \cos(2\pi ft) + i\frac{m\Delta}{f}\sin(2\pi ft) \end{pmatrix}, \quad (13)$$

$$f = \sqrt{\Delta^2 + k^2 + m^2\Delta^2}. \quad (14)$$

Here, we have normalized Planck's constant to 1. Equating Eqs. (7) and (13), and simplifying terms, we obtain the following conditions to realize the unitary operation:

$$m = -\frac{\sin\left(\frac{\beta+\delta}{2}\right)\cos\left(\frac{\gamma}{2}\right)}{\sin\left(\frac{\gamma}{2}\right)\sin\left(\frac{\beta-\delta}{2}\right)}, \quad (15)$$

$$k \sin\left(\frac{\beta-\delta}{2}\right) = -\Delta \cos\left(\frac{\beta-\delta}{2}\right), \quad (16)$$

$$\sqrt{(\Delta^2 + k^2 + m^2\Delta^2)} = \frac{\cos^{-1}\left(\cos\left(\frac{\beta+\delta}{2}\right)\cos\left(\frac{\gamma}{2}\right)\right)}{2\pi T}. \quad (17)$$

Here, T is the time step within which the desired unitary operation is to be realized. Given the values of  $\beta$ ,  $\delta$ , and  $\gamma$ , Eqs. (15) through (17) can now be solved to find the parameters to realize different unitary gate operations. All parameters except  $\varepsilon_B$ , will be treated as fixed constants of the system, while implementing a gate operation. Figure 2 shows the bias that will be applied on the target qubit, B, for a time step T, during which the gate operation is realized. The magnitude of the bias will be " $\xi_1 + \xi_2 + m\Delta$ " as given by Eq. (8).

As an example, suppose we wish to realize a Toffoli gate,  $C^2(\mathbf{X})$ , in which case the  $\mathbf{U}$  matrix given by Eq. (7) is the **NOT** gate (denoted by  $\mathbf{X}$ ), where

$$\mathbf{X} = \begin{bmatrix} 0 & 1 \\ 1 & 0 \end{bmatrix}. \quad (18)$$

One set of values for the angles  $\beta$ ,  $\delta$ , and  $\gamma$  are  $\pi$ , 0 and  $\pi$ , respectively. From Eqs. (15) and (16), we have  $m = 0$  and  $k = 0$  (which is typical for Josephson-junction qubits. Note that for  $\beta = \delta = 0$ , and  $\gamma = \pi$ , we have  $m = 0$  and  $\Delta = 0$ .) If we choose the time step, T, of the gate operation to be 10ns, then from Eq. (17), we find  $\Delta$  to be 25MHz, which is a typical value for the tunneling parameter of SQUIDs [44]. Since  $\xi_1$  ( $\xi_2$ )  $\gg \Delta$ , we choose  $\xi_1$  and  $\xi_2$  to be 400MHz and 200MHz, respectively. These values are arbitrarily chosen such that under each of the Hamiltonians given by Eqs. (9) through (11), qubit B undergoes Z rotations that are integer multiples of  $2\pi$  within the time step, T. Under the Toffoli gate operation, the bias on qubit B is pulsed from zero to 600MHz (Eq. (8) with  $m=0$ ) for 10ns. That is, in Fig. 2, the magnitude of the bias pulse is 600MHz and the time step is 10ns. Observe that the biases on qubits A and C remain zero throughout the operation, and need not be varied, which is an advantage. Numerical simulations of the  $8 \times 8$  Hamiltonian verify this technique, with a maximum error of 0.93% in the output probability amplitudes. It is important to point that, since the reduced-Hamiltonian technique uses the approximation  $\xi_1$  ( $\xi_2$ )  $\gg \Delta$  in finding an analytic solution for calculating the system parameters,

stronger the coupling, greater is the fidelity of the gate operation. For instance, if  $\xi_1$  and  $\xi_2$  are 2GHz and 1GHz, respectively, the maximum error in the output probability amplitudes is 0.04%. However, in this case, the bias on target B will have to be raised to 3GHz.

Likewise, suppose we want to implement a controlled-controlled-Hadamard gate,  $C^2(\mathbf{Had})$ , where the Hadamard gate,  $\mathbf{Had}$ , is defined by the following matrix operation:

$$\mathbf{Had} = \frac{1}{\sqrt{2}} \begin{bmatrix} 1 & 1 \\ 1 & -1 \end{bmatrix}. \quad (19)$$

Since the tunneling is a fixed parameter of our system, we will use the same value of  $\Delta$  and  $k$  as we previously derived for the Toffoli gate, i.e.,  $\Delta = 25\text{MHz}$ ,  $k=0$ . One set of values for  $\beta$ ,  $\delta$  and  $\gamma$  to realize a  $\mathbf{Had}$  gate are  $2\pi$ ,  $\pi$  and  $\pi/2$ , respectively. Note from Eq. (16) that these values of the angles satisfy the condition  $k = 0$ . Also, from Eq. (15), we have  $m = 1$ . Using Eq. (17), we calculate  $T$  to be 7.1ns. Therefore, to implement a  $C^2(\mathbf{Had})$  gate, the bias on qubit B is pulsed from zero to 625MHz (Eq. (8) with  $m=1$ ) for 7.1ns. That is, in Fig. 2, the magnitude of the bias on qubit B is 625MHz, and  $T$  is 7.1ns. Observe that for both gate operations we used the same value of the couplings, i.e., the couplings are fixed. This has the advantage that even in a system with tunable couplings, the values of the couplings need to be adjusted only at the start of a computation, which can greatly reduce the circuit complexity, and the number of computational steps.

In most quantum systems, gate operations themselves are not realized perfectly, due to the structure of the internal Hamiltonian. For instance, observing Eq. (13), an  $\mathbf{X}$  gate or  $\mathbf{Had}$  gate is realized with an overall global phase of  $\pm \pi/2$  for  $k=0$ . As a result, the  $|101\rangle$  and  $|111\rangle$  states pick up relative phases of  $\pm \pi/2$  with respect to the other basis states when implementing a Toffoli (or  $C^2(\mathbf{Had})$ ) gate. To overcome these phases we require an additional coupling parameter,  $\xi$ , between qubits A and C. However, this additional “next-to-nearest-neighbor” coupling, if present, affects the gate operation itself, unless accounted for when applying the bias pulses on the target qubit. Details of the effects of next-to-nearest-neighbor couplings on gate operations have been presented elsewhere.

We will next show how to use our scheme to implement two-qubit controlled-unitary operations and single-qubit unitary operations. Two-qubit controlled-unitary operations,  $C^1(\mathbf{U})$ , can be realized by applying two pulses as shown in Fig. 3(a). Suppose we want to perform a  $C^1(\mathbf{U})$  gate with qubit A as the control qubit and qubit B as the target qubit. Qubit C behaves as the “dummy” qubit in this case. The first pulse on target qubit B is a bias value of “ $\xi_1 + \xi_2 + m\Delta$ ” (Eq. (8)). For the second pulse, the bias on target qubit B is raised to a value of “ $\xi_1 - \xi_2 + m\Delta$ ”. This is because, in this case, we want qubit B to undergo a unitary operation (Eq. (7)) under the reduced Hamiltonian given by Eq. (5). Similarly, to realize a single qubit unitary operation, four pulses are applied. The values of the bias pulses on qubit B will be “ $-\xi_1 - \xi_2 + m\Delta$ ”, “ $-\xi_1 + \xi_2 + m\Delta$ ”, “ $\xi_1 - \xi_2 + m\Delta$ ”, and “ $\xi_1 + \xi_2 + m\Delta$ ”, respectively, for the four gate operations shown in Fig. 3(b). Observe that unlike some previous methods that use “isolation” qubits (qubits fixed in  $|0\rangle$  and  $|1\rangle$  states) to separate the qubits used in the gate operations

from their nearest neighbors, our scheme has no such requirement. This is a great advantage for two reasons – the same gate operation can be realized without using additional qubits, and swap gate operations are not required to bring together qubits separated by “isolation” qubits.

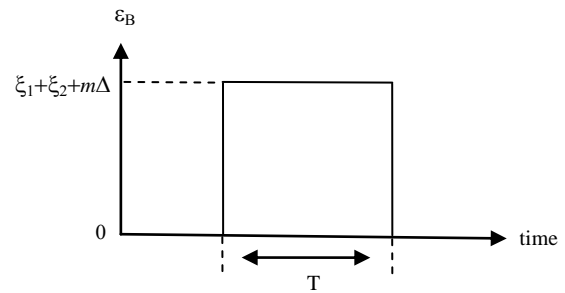

Figure 2. Bias pulse on the target qubit, B, during a  $C^2(\mathbf{U})$  gate operation on a three-qubit system. The bias is raised from zero to a value “ $\xi_1 + \xi_2 + m\Delta$ ” as given by Eq. (8). The biases on control qubits, A and C, are kept zero throughout the gate operation.

As shown, the reduced-Hamiltonian technique presented here allows experimentalists the ability to choose system parameters to realize quantum gates, for ideal pulses. However, in real systems, pulses are not ideal. Given non-ideal characteristics, experimentalists can fine-tune control parameters through numerical simulation, as shown in [45] and [46]. For example, real pulses exhibit finite rise ( $T_R$ ) and fall ( $T_F$ ) times. Simulations carried out for the Toffoli gate under different values of  $T_R$  and  $T_F$  show that, under a non-ideal pulse, to increase the fidelity of a Toffoli gate, the pulse width has to be increased. For instance, when  $\epsilon_B = 600\text{MHz}$ , for  $T_R = T_F = 1\text{ns}$ , the pulse width becomes 10.4ns, instead of 10ns as originally calculated. In this case, the maximum error in the output probability amplitudes is 2.97%. If, however,  $\epsilon_B = 3\text{GHz}$  (for  $\xi_1=2\text{GHz}$ ;  $\xi_2=1\text{GHz}$ ), for  $T_R = T_F = 1\text{ns}$ , the pulse width is 10.7ns, giving a maximum error of 0.54% in the output probability amplitudes. Even though the probability amplitudes can be improved by adjusting the pulse width, random relative phases occur between the basis states in the final state. These phases are hard to keep track of since they vary with the rise/fall times and the maximum amplitude of the bias pulse. However, in [47], we present an architectural layout of qubits that is immune to such relative phase errors.

While we have restricted our discussion to LNN architectures where the qubits are coupled via Ising interactions, the method presented here easily extends to systems coupled via Heisenberg interactions. Equation (20) shows a three-qubit system coupled via anisotropic interactions [48].

$$\mathbf{H} = \sum_{i=A,B,C} \left( \Delta \sigma_{x_i} + k \sigma_{y_i} + \epsilon_i \sigma_{z_i} \right) + \xi_1 \left( \sigma_{z_A} \sigma_{z_B} + \alpha \left( \sigma_{x_A} \sigma_{x_B} + \sigma_{y_A} \sigma_{y_B} \right) \right) + \xi_2 \left( \sigma_{z_B} \sigma_{z_C} + \alpha \left( \sigma_{x_B} \sigma_{x_C} + \sigma_{y_B} \sigma_{y_C} \right) \right) \quad (20)$$

If  $\alpha \ll 1$ , i.e., the off-diagonal  $\sigma_X \sigma_X$  and  $\sigma_Y \sigma_Y$  couplings are much smaller than the diagonal  $\sigma_Z \sigma_Z$  couplings, the

interactions are pre-dominantly of the Ising type. Therefore, the same parameters that were used to realize a  $C^2(\mathbf{U})$  operation in a system described by Eq. (5), can be used to realize the operation in a system described by Eq. (20). For instance, consider the Toffoli gate. The coupling parameters,  $\xi_1$  and  $\xi_2$ , are 400MHz and 200MHz, respectively. Simulation results showed that when  $\alpha$  was 0.01, 0.05, and 0.1, the maximum error in the output probability amplitudes were 0.3%, 1.64%, and 11.36% respectively. The high error in the probability amplitude when  $\alpha$  is 0.1 is because, the magnitudes of the  $\sigma_X\sigma_X$  and  $\sigma_Y\sigma_Y$  couplings are much larger than the tunneling parameter. As a result, the high off-diagonal couplings cause the control qubits to undergo unitary dynamics that are no longer simple Z rotations. In other words, the control qubits no longer remain in their states, but actually can change their state from  $|0\rangle$  to  $|1\rangle$ , and vice versa, with a probability that depends on the value of  $\alpha$ . Moreover, it was also found that by decreasing the pulse width of the gate operation, a higher accuracy can be obtained. For  $\alpha = 0.1$ , when T was reduced to 8.4ns, the maximum error in the output probability amplitudes was reduced to 4.9%. Next, for  $\alpha = 0.05$ , the off-diagonal couplings are almost equal to the tunneling, which results in a much lower error. Here again, by reducing T (9.2 ns), a much lower error in the output probability amplitudes can be obtained (0.6%). Finally, for  $\alpha = 0.01$ , the error is very low since the off-diagonal couplings are lower than the tunneling. Therefore, they have a negligible effect on the evolution of the system as a whole.

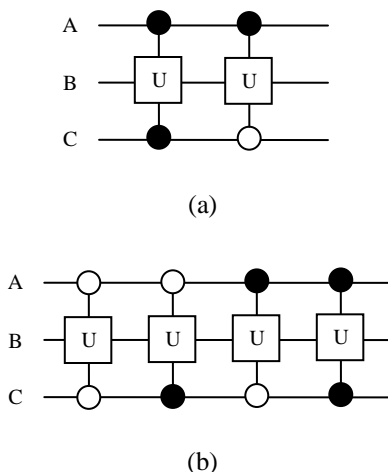

Figure 3. Methods for realizing a two-qubit controlled-unitary operation and a single-qubit unitary operation. (a) Qubit A is the control and qubit B is the target. Qubit C functions as a dummy qubit. The overall gate operation requires 2 pulses. (b) Qubit B is the qubit on which a unitary operation is to be performed. Qubits A and C are dummy qubits. The gate operation is realized in four pulses, each of which corresponds to a  $C^2(\mathbf{U})$  gate operation.

In a previous reduced-Hamiltonian scheme for weakly coupled qubits [44], we showed how to implement two-qubit controlled-unitary operations,  $C^1(\mathbf{U})$ , without having to shut off coupling between qubits. This approach required that the bias on the control qubit be maintained at an arbitrarily large value throughout the gate operation, and the bias on the target qubit be pulsed low during the gate operation [44]. While the scheme

worked at achieving arbitrary  $C^1(\mathbf{U})$  operations, it had two disadvantages. The first was that the high value of the bias on the control qubit during  $C^1(\mathbf{U})$  operations caused the control qubit to precess at very fast rates. Therefore, slight mismatches in timing or in the bias parameter gave rise to large variations in the relative phases between the basis states. The second, and more important disadvantage, was that the scheme could not be generalized towards realizing controlled-unitary operations on a target qubit involving more than two control qubits, i.e.,  $C^N(\mathbf{U})$  with  $N > 2$ . In the scheme presented here, once the values of  $m$ ,  $\Delta$ ,  $k$  and  $T$  are found by solving Eqs. (15) through (17), a  $C^N(\mathbf{U})$  operation, for any value of  $N \geq 1$ , can be simply realized by raising the bias on the target qubit from zero to a value given by

$$\varepsilon = m\Delta + \sum_{i=1}^N \xi_i. \quad (21)$$

where  $\xi_i$  are the couplings between the target qubit and each of the  $N$  control qubits. No two couplings can have the same magnitude as the target qubit will not be able to distinguish between the different control qubits. Equation (21) shows that, as  $N$  varies, the values of  $m$ ,  $\Delta$ ,  $k$  and  $T$  do not change for a desired unitary operation given by Eq. (11). Only the bias varies according to the number of coupling terms in Eq. (21). (Note that since  $\xi_i \gg \Delta$ , for  $i = 1, \dots, N$ , the values of  $\xi_i$  are chosen such that " $\xi_i T$ " is an integer multiple of  $2\pi$ , so that an identity operation is realized on the target qubit when all the control qubits are not in the  $|1\rangle$  state). Thus, the scheme can be easily extended to 2-dimensional layouts and to architectures where couplings are not restricted to nearest neighbors.

The scheme presented here has yet another advantage. Single qubit Z rotations can be easily realized by varying the biases on individual qubits. For instance, an  $R_Z(\theta)$  gate, which is a Z rotation by angle  $\theta$ , can be realized on qubit A (B or C), by raising the bias slightly on it to a value  $\varepsilon_A$  ( $\varepsilon_B$  or  $\varepsilon_C$ ) such that  $2\pi \varepsilon_A T = \theta$ , where  $T$  is the time within which the rotation is realized. Since the scheme in [44] required high biases on all qubits during idle times, it was difficult to perform single qubit rotations, especially since qubits were precessing at very fast rates and relative phases were difficult to control. Moreover, the scheme presented here, where the couplings are larger and chosen so that within a 10ns interval no phases occur, the small magnitudes of the always-on couplings in [44] always generate additional phases, which are hard to keep track of through timing.

It is important to point out that while in this work we have assumed the qubits to be identical in design with no asymmetries in the architectural layout, relative phases can occur as a result of parameter mismatches, which might alter the results of a computation. The performance of gate operations in the presence of parameter mismatches and asymmetry in design is being considered as a future work.

### III. CONCLUSIONS

In this paper, we have presented a new reduced-Hamiltonian scheme for implementing universal quantum computation in strongly coupled multi-qubit systems. The technique provides analytic solutions to the time evolution of

the system, so that system parameters can easily be solved for, to realize desired quantum gates. The scheme is general and can be extended towards any two-level system whose Hamiltonian can be reduced to that of a spin boson. We described how to implement gate operations in a one-dimensional NN architecture, where the effects of finite rise and fall times due to non-ideal pulses on gate operations were considered. The scheme was then extended to show how a controlled-unitary operation with N controls and a single target qubit can be realized in a single pulse. The main advantage of the scheme presented in this paper is that it is simple and efficient because only a single control parameter is required. Also, we do not require the ability to tune couplings during a computation. Moreover, unlike some other methods, neither does ours' require encoding physical qubits into logical qubits, nor does it require separating qubit-bearing spins by passive "barrier" spins, thereby, significantly minimizing the computational overhead.

#### ACKNOWLEDGMENT

This material is based upon work supported, in part, by the National Science Foundation under Award No. EPS-0903806 and matching support from the State of Kansas through Kansas Technology Enterprise Corporation.

#### REFERENCES

- [1] B. E. Kane, "A silicon-based nuclear spin quantum computer," *Nature London*, vol. 393, pp. 133-136, May 1998.
- [2] A. J. Skinner, M. E. Davenport and B. E. Kane, "Hydrogenic spin quantum computing in silicon: a digital approach," *Phys. Rev. Lett.*, vol. 90, pp. 087901-087904, February 2003.
- [3] L. C. L. Hollenberg, *et al.*, "Charge-based quantum computing using single donors in semiconductors," *Phys. Rev. B*, vol. 69, pp. 113301-113304, March 2004.
- [4] K. Yang, S. Zhu, and Z. Wang, "Universal quantum gates based on both geometric and dynamic phases on quantum dots," *Chinese Phys. Lett.*, vol. 20, pp. 991-994 (2003).
- [5] J. K. Pachos and P. L. Knight, "Quantum computation with a one-dimensional optical lattice," *Phys. Rev. Lett.*, vol. 91, pp. 107902-107905, September 2003.
- [6] M. Friesen, *et al.*, "Practical design and simulation of silicon-based quantum-dot qubits," *Phys. Rev. B*, vol. 67, pp. 121301-121304 (R), March 2003.
- [7] P. Solinas, P. Zanardi, N. Zanghi and F. Rossi, "Semiconductor-based geometric quantum gates," *Phys. Rev. B*, vol. 67, pp. 121307-121310 (R), March 2003.
- [8] J. H. Jefferson, M. Fearn and D. L. J. Tipton, "Two-electron quantum dots as scalable qubits," *Phys. Rev. A* 66, pp. 042328-042338, October 2002.
- [9] V. N. Golovach and D. Loss, "Electron spins in artificial atoms and molecules for quantum computing," *Semicond. Sci. Tech.*, vol. 17, pp. 355-366, March 2002.
- [10] T. D. Ladd, J. R. Goldman, F. Yamaguchi and Y. Yamamoto, "All-silicon quantum computer," *Phys. Rev. Lett.*, vol. 89, pp. 017901-017904, June 2002.
- [11] B. Golding and M. I. Dykman, "Acceptor-based silicon quantum computing," *cond-mat/0309147*, September 2003.
- [12] E. Novais and A. H. Castro Neto, "Nuclear spin qubits in a pseudospin quantum chain," *Phys. Rev. A*, vol. 69, pp. 062312-062317, June 2004.
- [13] R. Vrijen, *et al.*, "Electron-spin-resonance transistors for quantum computing in silicon-germanium heterostructures," *Phys. Rev. A*, vol. 62, pp. 012306-012315, June 2000.
- [14] L. Tian and P. Zoller, "Quantum computing with atomic Josephson-junction arrays," *Phys. Rev. A*, vol. 68, pp. 042321-042330, October 2003.
- [15] L. M. K. Vandersypen, *et al.* in *Quantum Computing and Quantum Bits in Mesoscopic Systems*, edited by A. J. Leggett, B. Ruggiero, and P. Silvestrini (Kluwer Academic/Plenum Publishers, New York, 2003).
- [16] V. V'yurkov and L. Y. Gorelik, "Charge based quantum computer without charge transfer," *Quant. Comput. and Comput.*, vol. 1, pp. 77-83, 2000.
- [17] N.-J. Wu, M. Kamada, A. Natori, and H. Yasunaga, "Quantum computer using coupled-quantum-dot molecules," *Jpn. J. Appl. Phys.* 39, pp. 4642-4646, 2000.
- [18] S. H. W. van der Ploeg *et al.*, "Controllable coupling of superconducting flux qubits," *Phys. Rev. Lett.*, vol. 98, pp. 057004-057007, February 2007.
- [19] J. Lantz, M. Wallquist, V. S. Shumeiko, and G. Wendin, "Josephson junction qubit network with current-controlled interaction," *Phys. Rev. B*, vol. 70, pp. 140507-140510 (R), October 2004.
- [20] R. Stock and D. F. V. James, "Scalable, high-speed measurement-based quantum computer using trapped ions," *Phys. Rev. Lett.*, vol. 102, pp. 170501-170504, April 2009.
- [21] D. Jaksch, "Optical lattices, ultracold atoms and quantum information processing," *Contemp. Phys.*, Vol 45, pp. 367-381, September 2004.
- [22] D. P. DiVincenzo, "Fault tolerant architectures for superconducting qubits," *Nobel Symposium on Qubits for Quantum Information*, arXiv:0905.4839 (2009).
- [23] R. Van Meter, T. D. Ladd, A. G. Fowler, and Y. Yamamoto, "Distributed quantum computation architecture using semiconductor nanophotonics," *Int. J. Quantum Inf.*, vol. 8, pp. 295-323, 2010.
- [24] N. C. Jones, *et al.*, "A layered architecture for quantum computing using quantum dots," arXiv:1010.5022, 2009.
- [25] A. G. Fowler, "Two-dimensional color-code quantum computing," *Phys. Rev. A*, vol. 83, pp. 042310-042317, April 2011.
- [26] D. M. Hugh, and J. Twamley, "Quantum computing using a trapped-ion spin molecule and microwave radiation," *Phys. Rev. A*, vol. 71, pp. 012315-012320, January 2005.
- [27] C. J. Wellard, L.C.L. Hollenberg, L.M. Kettle, and H-S Goan, "Voltage control of exchange coupling in phosphorus doped silicon," *J. Phys.: Condens. Matter* 16, No. 32, pp. 5697-5704, 2004.
- [28] E. A. Stinaff, *et al.*, "Optical signatures of coupled quantum dots," *Science*, vol. 311, pp. 636-639, January 2006.
- [29] S. Ashhab, and F. Neri, "Switchable coupling for superconducting qubits using double resonance in the presence of cross talk," *Phys. Rev. B*, vol. 76, pp. 132513-132516, October 2007.
- [30] A. O. Niskanen, *et al.*, "Quantum coherent tunable coupling of superconducting qubits," *Science*, vol. 316, pp. 723-726, March 2007.
- [31] D. P. DiVincenzo, G. Burkard, D. Loss, and E. V. Sukhorukov, in *Quantum Mesoscopic Phenomena and Mesoscopic Devices in Microelectronics*, edited by I.O. Kulik and R. Ellialtuglu (NATO ASI, Turkey, June 13-25, 1999); *cond-mat/99112445*.
- [32] D. P. DiVincenzo, D. Bacon, J. Kempe, G. Burkard, and K. B. Whaley, "Universal quantum computation with the exchange interaction," *Nature*, vol. 408, pp. 339-342, October 2000.
- [33] G. P. Berman, G. D. Doolen, and V. I. Tsifrinovich, "Solid-state quantum computation: a new direction for nanotechnology," *Superlattices and Microstructures*, vol. 27, pp. 89-104, February 2000.
- [34] G. P. Berman, G. D. Doolen, D. I. Kamenev, and V. I. Tsifrinovich, in: *Quantum Computation and Information*, *Complementary Mathematics* 305, 13, 2002.
- [35] X. Zhou, Z. Zhou, G. Guo and M. J. Feldman, "Quantum computation with untunable couplings," *Phys. Rev. Lett.*, vol. 89, pp. 197903-197906, October 2002.
- [36] S.C. Benjamin, and S. Bose, "Quantum computing with an always-on Heisenberg interaction," *Phys. Rev. Lett.*, vol. 90, pp. 247901-247904, June 2003.

- [37] R. Raussendorf, "Quantum computation via translation-invariant operations on a chain of qubits," *Phys. Rev. A*, vol. 72, pp. 052301-052306, November 2005.
- [38] J. Fitzsimons, and J. Twamley, "Globally controlled quantum wires for perfect qubit transport, mirroring, and computing," *Phys. Rev. Lett.*, vol. 97, pp. 090502-090505, September 2006.
- [39] B. W. Lovett, "Global optical control of a quantum spin chain," *New J. of Phys.*, vol. 8, p. 69, May 2006.
- [40] F. Troiani, M. Affronte, S. Carretta, P. Santini, and G. Amoretti, "Proposal for quantum gates in permanently coupled antiferromagnetic spin rings without need of local fields," *Phys. Rev. Lett.*, vol. 94, 190501-190504, May 2005.
- [41] G.F. Mkrtchian, "Universal quantum logic gates in a scalable Ising spin quantum computer," *Phys. Lett. A*, vol. 372, pp. 5270-5273, August 2008.
- [42] T. Yamamoto, Y.A. Pashkin, O. Astafiev, Y. Nakamura, and J.S. Tsai, "Demonstration of conditional gate operation using superconducting charge qubits," *Nature*, vol. 425, pp. 941-944, October 2003.
- [43] M. A. Nielsen and I. L. Chuang, *Quantum Computation and Quantum Information* (Cambridge University Press, Cambridge, England, 2001).
- [44] P. Kumar and S. R. Skinner, "Simplified approach to implementing controlled-unitary operations in a two-qubit system," *Phys. Rev A*, vol. 76, pp. 022335-022345, August 2007.
- [45] P. K. Gagnebin, *et al.*, "Quantum gates using a pulsed bias scheme," *Phys. Rev A*, vol. 72, pp. 042311-042319, October 2005.
- [46] P. Kumar and S. R. Skinner, "Universal quantum computing in linear nearest neighbor architectures," *Quant. Inf. and Comput.*, vol. 11, pp. 0300-0312, March 2011.
- [47] P. Kumar, S. R. Skinner, and S. Daeizadeh, "Nearest-neighbor architecture to overcome effects of qubit precessions in gate operations," *IEEE Congress on Evolutionary Computation*, June 2011, "in press".
- [48] J. Zhang and K. B. Whaley, "Generation of quantum logic operations from physical hamiltonians," *Phys. Rev. A*, vol. 71, pp. 052317-052329, May 2005.