

A k -Resilient Node Deployment Scheme Using an Air Vehicle in Wireless Sensor Networks

Daehee Kim and Sunshin An
 Department of Electronics Engineering
 Korea University, Seoul, Republic of Korea
 e-mail: {dhkim, sunshin}@dsys.korea.ac.kr

Abstract— Since wireless sensor networks (WSNs) are susceptible to physical node capture attacks, it is not sufficient to use cryptography for secure communications in WSNs. To resolve this problem, we propose a node deployment scheme using an air vehicle which tolerates up to k compromised nodes, called k -resilience. Our scheme models the environmental effect as Gaussian distribution and deploys sensor nodes using an air vehicle to statistically ensure k -resilience. We also show how well our scheme guarantees k -resilience through a simulation in MATLAB.

Keywords— node deployment; k -resilience; air vehicle; WSNs

I. INTRODUCTION

Wireless sensor networks (WSNs) are vulnerable to physical node capture attacks since WSNs are usually deployed in the hostile environment and operated unattended for a long time. Hence, cryptography-based secure communications are not enough for WSNs. One of the most widely used solutions is to take advantage of redundancy [1]. Suppose that a sensor node A has three neighbors, one of which is compromised by an adversary, thus two nodes send correct information and a compromised node send false information. In this case, the sensor node A can get correct information by selecting the median value among the received messages. More generally, each node requires $2k+1$ neighbors to guarantee k -resilience, which tolerates up to k compromised nodes.

The easiest way to guarantee k -resilience is a deterministic deployment which takes too much effort and is almost impossible in large-scale WSNs. In contrast, deploying sensor nodes randomly needs too many sensor nodes to guarantee k -resilience [2]. To meet halfway, we propose a k -resilient node deployment scheme using an air vehicle. We first model the environmental effect such as wind using Gaussian distribution, and thus the real position of the dropped node from the air vehicle is statistically determined. With this statistical information, we propose a node deployment scheme to statistically guarantee k -resilience. Finally, we show that our scheme guarantees k -resilience through a simulation in MATLAB and compare the required number of nodes for k -resilience with the deterministic deployment and the random deployment.

The rest of this paper is organized as follows. Section II describes the assumptions and proposes our scheme. After evaluating our scheme in Section III, Section IV concludes this paper.

II. STATE OF THE ART

The node deployment schemes in WSNs can be classified into three categories: 1) Deterministic deployment, 2) Random deployment, and 3) Controlled random deployment [2]. The deterministic deployment can easily achieve k -resilience by manually deploying k nodes within the transmission range of each node. However, this needs too much effort and is almost impossible in large-scale WSNs. In contrast, the random deployment requires too many nodes to guarantee k -resilience [3]. The controlled random deployment [2] locates each node from the air vehicle considering wind effect, which balances between the deterministic and random deployment in terms of feasibility and the required number of nodes. However, it does not take k -resilience into account.

Compared with other schemes, our scheme not only statistically guarantees k -resilience considering the environmental effect, but also efficient from the perspective of the required number of nodes.

III. PROPOSED SCHEME

A. Assumptions

We assume that each sensor node is deployed in the 2-dimensional area from the air vehicle which moves at a fixed height of h , with a constant velocity v in parallel to the axis X as shown in Figure 1. While dropping, a sensor node is affected by the environmental effect, mainly wind, which is assumed to conform to Gaussian distribution of $E \sim N(\mu, \sigma^2)$.

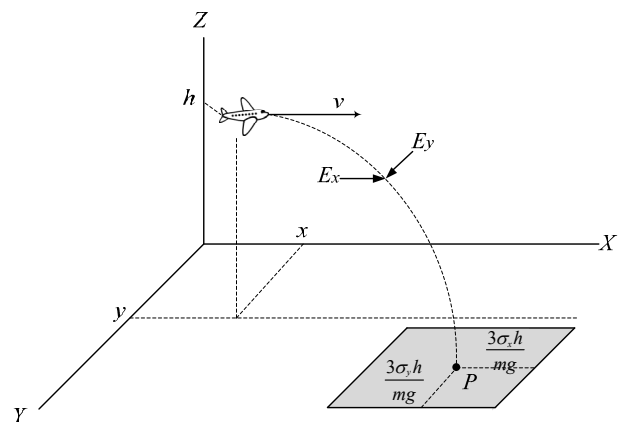

Figure 1. Example of dropping a sensor node from an air vehicle.

For simplicity, we assume that the environmental effect is also 2-dimensional and thus the E is divided to $E_x \sim N(\mu_x, \sigma_x^2)$ and $E_y \sim N(\mu_y, \sigma_y^2)$. Finally, each sensor node is assumed to have a fixed transmission range of R .

B. k -Resilient Node Deployment Scheme

As stated previously, we select a node deployment scheme using an air vehicle to find a balance between the deterministic deployment and the random deployment.

When a sensor node is dropped from an air vehicle as depicted in Figure 1, the most probable position P is

$$P = \left(x + \frac{\mu_x h}{mg} + v \sqrt{\frac{2h}{g}}, y + \frac{\mu_y h}{mg}, 0 \right) \quad (1)$$

where g is the gravitational acceleration, and (x, y) is the position of the air vehicle. The second term and third term in the x-coordinate of (1) are from the environmental effect and the velocity, respectively. The second term in the y-coordinate of (1) is due to the environmental effect. Under our assumption that the environmental effect conforms to Gaussian distribution, we can compute a rectangle where a node is really located with a probability of 99.7% using $\mu_x \pm 3\sigma_x$ and $\mu_y \pm 3\sigma_y$ instead of μ_x and μ_y in (1). Then, as shown in Figure 1, the shaded rectangle S becomes

$$S = \left[x + \frac{(\mu_x - 3\sigma_x)h}{mg} + v \sqrt{\frac{2h}{g}}, x + \frac{(\mu_x + 3\sigma_x)h}{mg} + v \sqrt{\frac{2h}{g}} \right] \\ \times \left[y + \frac{(\mu_y - 3\sigma_y)h}{mg}, y + \frac{(\mu_y + 3\sigma_y)h}{mg} \right] \quad (2)$$

Using the fact that the real position of the dropped node is bounded by the rectangle, which has a width of $6\sigma_x h/mg$ and a height of $6\sigma_y h/mg$, with a confidence probability of 99.7%, we try to develop a k -resilient node deployment scheme. Suppose a circle centered at a node A with a transmission range of R as Figure 2. As mentioned earlier, each node must have $2k+1$ neighbors to guarantee k -resilience, which tolerates up to k compromised nodes. Without the environmental effect, we only need to deploy $2k+2$ nodes within the outer circle in Figure 2. However, the circle should be shrunken to the inner circle by σ_{max} which can ensure that $2k+2$ nodes are located within the outer circle with a confidence probability of at least 99.7%. To deploy $2k+2$ nodes within the inner circle, we compute a distance d between neighboring nodes as follows [4].

$$d = \sqrt{\frac{\pi(R - \sigma_{max})^2}{2k+2}}, \quad \text{where } \sigma_{max} = \max\left(\frac{3\sigma_x h}{mg}, \frac{3\sigma_y h}{mg}\right) \quad (3)$$

Given d , we begin to deploy sensor nodes. Suppose that the area to be deployed is a rectangle from $(0, 0)$ to (x_{max}, y_{max}) . Deployment proceeds from $(0, 0)$ to $(x_{max}, 0)$ in parallel with the axis X . To locate the first sensor on $(0, 0)$, an air vehicle is firstly located at

$$\left(-\frac{\mu_x h}{mg} - v \sqrt{\frac{2h}{g}}, -\frac{\mu_y h}{mg}, h \right) \quad (4)$$

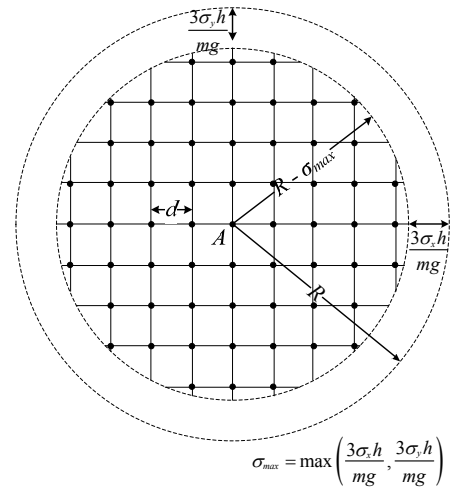

Figure 2. Deployment of $2k+2$ nodes to guarantee k -resilience.

TABLE I. THE NUMBER OF REQUIRED SENSOR NODES FOR k -RESILIENCE

Scheme	Number of Required Sensor Nodes	k -resilience
Our scheme	81225	100 %
Deterministic	76729	100 %
Random	125687	99.7 %

The air vehicle then moves with the velocity v in parallel to the axis X , and drops a sensor node every d/v second. When the air vehicle completes the deployment of the first line, the air vehicle moves to deploy the second line which is from (x_{max}, d) to $(0, d)$ aiming at

$$\left(x_{max} + \frac{\mu_x h}{mg} + v \sqrt{\frac{2h}{g}}, \frac{\mu_y h}{mg} + d, h \right) \quad (5)$$

Then, the air vehicle moves on the reverse direction of the axis X in parallel, and drops sensor nodes every d/v second. This procedure is repeated until the entire area is covered. Note that our scheme does not consider the boundary effect, which is left as a future work.

IV. EVALUATION

In this section, we evaluate our scheme through a simulation in MATLAB where k is 11, S is $10 \text{ km} \times 10 \text{ km}$, R is 100 meters, h is 100 meters, v is 50 km/hour, m is 100 grams, $E_x \sim N(100, 5)$, and $E_y \sim N(100, 10)$. Table I shows that all of three deployment schemes guarantee k -resilience, but our scheme requires much less sensor nodes than the random deployment. It is important to note that our scheme is originally designed to guarantee k -resilience with the confidence probability of 99.7%, but our scheme shows 100 % k -resilience as shown in Table I. This is because our scheme selects the inner circle conservatively as shown in Figure 2.

V. CONCLUSION

In this paper, we proposed a k -resilient node deployment scheme using an air vehicle which not only guarantees al-

most 100% k -resilience but also requires less number of sensor nodes than the random deployment. Our future work includes two things, one of which is to consider the boundary effect and the other is to perform the real profiling of the environment effect for determining σ_x and σ_y .

REFERENCES

- [1] K. Sun, P. Ning, and C. Wang, "Secure and resilient clock synchronization in wireless sensor networks," *IEEE J. sel. Areas Commun.*, vol. 24, no. 2, 2006, pp. 395-408.
- [2] N. Boudriga, "On a controlled random deployment WSN-based monitoring system allowing fault detection and replacement," *Int. J. Distrib. Sensor Netw.*, vol. 2014, 2014, pp. 1-13.
- [3] Y. Huang, J.-F. Martínez, J. Sendra, and L. López, "The influence of communication range on connectivity for resilient wireless sensor networks using a probabilistic approach," *Int. J. Distrib. Sensor Netw.*, vol. 2013, 2013, pp. 1-11.
- [4] W. Y. Poe and J. B. Schmitt, "Node deployment in large wireless sensor networks: coverage, energy consumption, and worst-case delay," *Proc. ACM AINTEC*, 2009, pp. 77-84.