

# Pipeline Monitoring and Spillage Prevention Using Wireless Sensors and High Density Polyethylene Pipe Encasement System 12

Mohammed Yusuf Agetegba  
College of Computer Science and Information Technology  
Sudan University of Science and Technology  
Khartoum, Sudan  
email: [mylislal@yahoo.com](mailto:mylislal@yahoo.com)

Pascal Lorenz  
University of Haute Alsace  
34 rue du Grillenbreit, Colmar - France.  
email: [pascal.lorenz@uha.fr](mailto:pascal.lorenz@uha.fr)

**Abstract**—Nigerian Niger Delta region is bedeviled with rampant oil spills, making it almost impossible for her indigenous people to enjoy economic activities derived from farming and fishing. Incessant oil thefts, corroded pipelines, vandalism, sabotage and extreme protests by sections of Niger Delta indigenous people are responsible for most oil spills in the region. Our proposed eco-friendly solution uses wireless motes and High Density Polyethylene Pipe System. While the former monitor attempts to vandalize encased crude oil pipelines, the latter collects crude oil seeping from corroded or damaged portions of encased steel or iron pipeline. This prevents spilled crude oil from causing ecological damage on land, rivers and seas in the region. Wireless sensors are arranged linearly within High Density Polyethylene Pipe System, linear clustering is adopted for rapid reporting within each cluster. Pipe monitoring is achieved by engaging light sensor of wireless motes, while crude oil spillage is detected and reported to mote using float switches.

**Keywords**—Monitoring; Sensors; Pipes; Cluster; Linear; Mote

each wireless node. Rather, power will be supplied to nodes from power banks which are strategically located along deployed pipeline route.

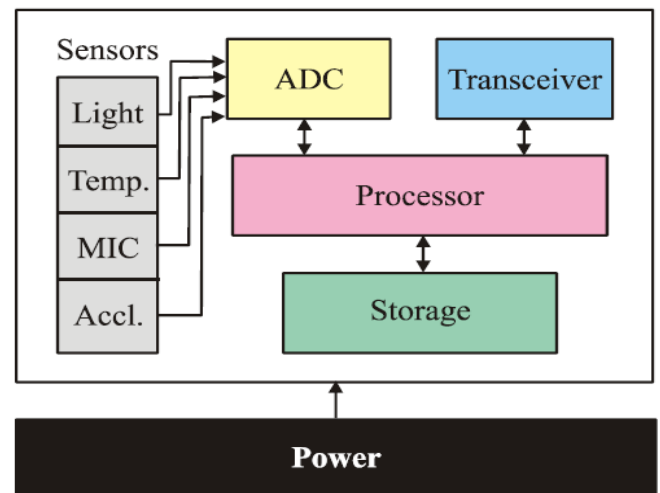

Figure 1. Wireless Sensor Node Architecture

## I. INTRODUCTION

Various projects [1][2][3][12] demonstrated the ability of wireless sensors to “sense” deployed environment and transmit “sensed” data to a central data collection gateway. Data packets are transmitted using multi-hop transmission from sender to receiver. This ensures packets hops along until it reaches intended destination (usually personal area network coordinator, abbreviated as PAN). Wireless sensor nodes are arranged within clusters to optimize both packet transmission and power consumption [4].

Essentially, a wireless node is a miniaturize computer which runs on low power, a typical sensor hardware comprises of one or more sensors, a signal conditioning unit, an analog to digital conversion module (ADC), a central processing unit (CPU), Memory, a radio transceiver and an energy power supply unit [5][6]. Wireless sensors are often encased in a protective housing which offers some level of protection against physical or chemical damage.

Advances in wireless sensor’s MAC layer has made it possible for sensor nodes to operate for a year or more on a pair of AA batteries [6][7][18][19]. However, due to the high cost of removing and replacing pipes in order to access and replace spent AA batteries, our proposed deployment environment will not rely on pairs of AA batteries to power

Sensors nodes typically adopt IEEE 802.15.4/ZigBee standard [8][9]. This standard introduces two types of devices within a wireless sensor network (WSN), a full-function device (FFD) and a reduced-function device (RFD). An FFD is capable of the following:

- Become a personal area network (PAN) coordinator which controls network initialization and manage the entire network.
- Become a coordinator, which removes network initialization, but retains complete management of entire network.
- Become a normal sensor device responsible for sensing deployed environment and forwarding sensed data to cluster’s PAN coordinator.

An RFD is used to perform simple tasks like connect to sensors and send collated readings to the network coordinator or PAN.

This research paper propose encasing pipelines within high density polyethylene (HDPE) pipes fitted with wireless sensors and float switches, making it easier to monitor both pipeline vandalism and oil spills.

To reduce cost, we propose using RFD sensors to both monitor ambient light and spilled crude oil within HDPE pipeline. Sensed data are forwarded via multi-hop to an FFD acting as the wireless sensor network (WSN) PAN coordinator.

This research encapsulates the effect of encasing crude oil within specially modified high density polyethylene (HDPE) pipes.

We modified the upper inner portion of the HDPE pipe to accommodate both FFD and RFD sensor (Figure 2) within separate compartments or segments. The lower portion of the pipe was equally modified to accommodate float switches and reusable spilled crude oil removal seal. The paper equally proposed powering sensors and float switches through external power banks, this ensures steady operations by eliminating periodic replacement of batteries powering each mote and requirement of opening of HDPE pipes to replace spent sensor AA batteries.

HDPE pipes were chosen for the following reasons:

- Resistance to corrosive chemicals available in crude oil
- Cheaper cost of manufacturing
- Fast and simple deployment options

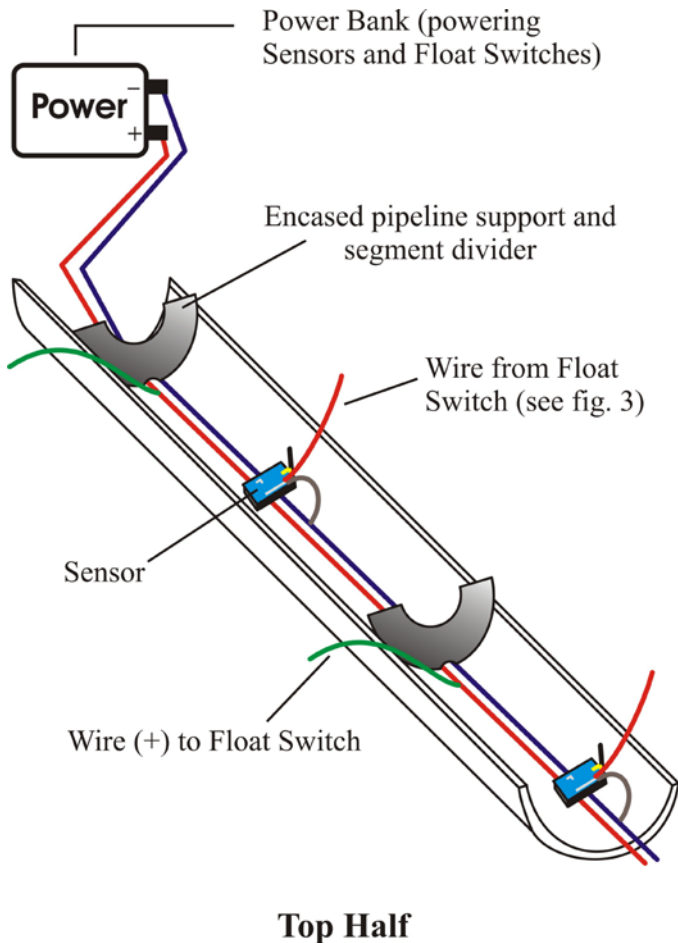

Figure 2. Top half of HDPE pipe fitted with sensors, wires conveying power and encased pipeline supports

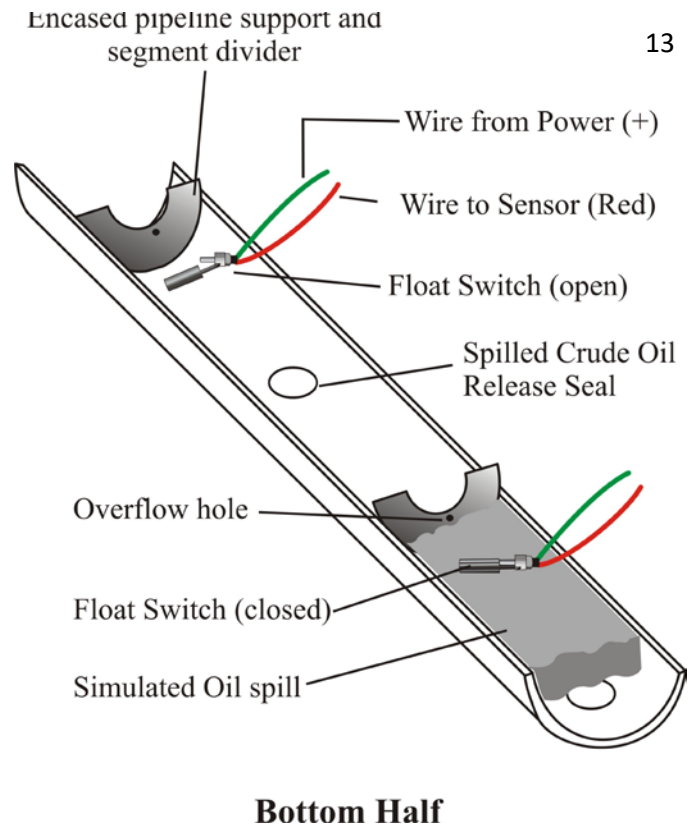

Figure 3. Bottom half of HDPE pipe fitted with float switches, wires conveying power and encased pipeline supports

The remaining part of this paper is organized as follows: Section II presents background motivation behind our proposal, along with details on the corrosive nature of crude oil, and inherent benefits of using HDPE pipes to encase oil pipelines. Section III examines current state of the art research in this field, which explores various methods used to monitor pipelines for vandalism, natural disaster, and leakages. While Section IV presents our proposed work. Section V presents and discusses the simulation results. Finally, Section VI concludes the paper with pointers to further research works.

## II. BACKGROUND

Generally, oil spills poses serious long-term ecological disaster in affected communities [10][1]. Oil spills occur when pipelines transporting crude oil ruptures; pipeline rupture occurs under the following circumstances: (1) rust resulting from corrosive crude oil, (2) rust as a result of aging pipes, (3) acts of vandalism and extreme economic protest (especially in places like Nigeria), and (4) equipment failure due to natural disasters (earthquakes or landslides) [10] [11].

A major challenge facing oil companies is inherent delay in detecting oil spills, such delay allow spilled crude oil to

spread further from the ruptured pipe, leading to greater ecological damage and expensive litigations/settlements.

Yarin [10] in his excellent work on crude oil corrosiveness; enumerated six components found in crude oil that makes it corrosive, these are summarized below:

- **Brackish Water (Chlorides):** Available in most crude oil, it contains the following chloride salts  $MgCl_2$ ,  $CaCl_2$  and  $NaCl$ . Preheating affected crude oil to a temperature higher than  $240^\circ F$  ( $120^\circ C$ ) breaks these salts down to  $HCl$ . However,  $HCl$  is only corrosive when it cools down to a temperature lower than morning dew, leading to the production of hydrochloric acid ( $H_2S$ ), which is highly corrosive. Listed below are various chemical degradations caused by these salts [10][11]:

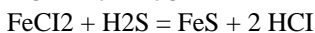
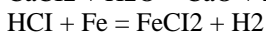
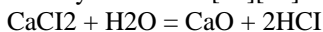

- **Carbon Dioxide ( $CO_2$ ):** When  $CO_2$  mixes with water, it produces a severely corrosive acid known as carbonic acid ( $H_2CO_3$ ). Carbonic acid is corrosive to normal steel pipes, however, it does not affect stainless steel pipes [10][11].
- **Phantom Chlorides (Organic Chlorides):** These salts decompose into  $HCl$  during preheating process. Corrosive actions triggered by these salts severely affect overhead or downstream units [10][11].
- **Organic Acids:** Naphthenic acid corrosion (NAC) occurs in refiner distillation units (furnace tubes, transfer lines, sidcut piping etc). Temperatures in these areas are between  $446^\circ F$  and  $752^\circ F$  ( $230^\circ C$  and  $400^\circ C$ ). Naphthenic acids react with steel to produce hydrogen as shown below [10][11]:

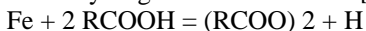

Presence of sulfides in crude oil causes  $Fe (RCOO)_2$  to react with  $H_2S$  and produce  $FeS$  as shown below [11]:



- **Sulfur:** Sulfides are highly corrosive to plain and alloy steel at temperatures higher than  $466^\circ F$  or ( $230^\circ C$ ), higher sulfidation occurs at higher temperatures, especially when  $H_2S$  decomposes to elemental sulfur [11].
- **Bacteria:** Microbiologically influenced corrosion (MIC) is widespread in oil and gas storage and transportation facilities. Sulfate reduction bacteria (SRB) are responsible for over 75% corrosion of such facilities in the US alone. SRB uses sulfate as an acceptor to create sulfide using the following reaction [10][11]:

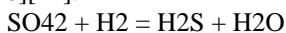

The foregoing reveals the possibility of oil spills occurring outside acts of vandalism. Such spills are caused when corrosive crude oil corrodes the pipeline along which it travels; this implies oil spills can happen anytime and anywhere. Hence the need to for an innovative research into what can be done to maintain the ecological balance along pipeline deployment routes. Encasing crude oil pipelines within a second protective and intelligent layer greatly reduce incidence of late detection of oil spills.

Interestingly, various HDPE pipes already convey crude oil. Tests [11] conducted by Shell International, The Hague, confirmed HDPE pipe can service pressure of up to 150 bar (2,175 psi) in temperatures of  $-30^\circ C$ . ( $-22^\circ C$ .) to  $30^\circ C$ . ( $86^\circ F$ .) According to [11], the pipe used in this test is manufactured by Tubes d'Aquitaine, Carsac, France, and supplied as Reinforced Thermo Plastic (RTP) pipe (see image below):



Figure 4. RTP pipe consists of a primary tube in HDPE (left), several crossed layers of Aramid yarns coated with HDPE (center), and an outer layer (right) of HDPE for external protection [13]

From the foregoing, our proposal to use HDPE pipes as encasement for existing or new crude oil pipelines is feasible.

### III. STATE OF THE ART

Several methods have been devised in order to monitor and report pipeline status. The most common and popular ones includes Acoustic Sensors – this employs acoustic or vibration measurement for pipeline monitoring [1][13][14][15]. Vision based systems – this is based on PIG (Pipeline Inspection Gauge) which must be inserted into the pipe. It works like image processor or laser scanner which main function is to detect leakages [13][15]. Ground penetrating radar (GPR) based systems – this is best suitable for use on environment with dry soil, but is not good for large network of pipes monitoring [13][14][15]. Fiber optic Sensors - this is suitable for present day pipeline monitoring systems, it can handle most present day pipelines issues, some of its drawbacks is the probability for redundancy and some challenges with deployment [13][16]. Multi modal underground wireless system – this uses low power, as the name implies it is meant for an underground installation, it has the advantage of camouflaging, but one of the disadvantages is that it has to be buried underground, that is a trench has to be created [13][15].

Every single Sensor has a distinctive feature and typical operating condition. Choosing a sensor for pipeline monitoring to a large extent depends on the environment to be deployed and the deployment method.

Our earlier work [1] proposed the following (1) concealing motes along buried pipeline route, while monitoring attempts to unearth the pipes, (2) attaching motes magnetically to exposed pipelines, while monitoring ambient sounds and vibrations coming from both pipeline and environ, (3) finally, we proposed a process for detecting when motes are damaged or stolen.

Ismail et al. [17] demonstrated the ability of IRIS and MICAZ mote to detect and record sounds while eliminating ambient noise levels. Their paper allows a parent mote to assign recording tasks to motes within their cluster.

Lou et al. [14] demonstrated the ability of MICAZ to detect and record environmental acoustics using the Microphone on MTS310CA sensor boards.

Kim et al. [15] also show the feasibility of using MICA based mobile wireless sensor with attached RFID in pipe line monitoring and maintenance.

This paper differs from [1][14][15][17] in the following areas: (1) It proposed an innovative solution which involves encasing existing or new crude oil pipelines within smart HDPE pipes. (2) Inner top layer of HDPE pipes are lined with motes and light sensors, while inner bottom layer of HDPE pipes are lined with float switches. (3) The paper breaks from related works since motes and light sensors monitors changes in ambient light, while motes respond to float switches interrupt during oil spills. (4) Unlike previous projects, this paper proposes external power source to power motes, external light sensors and float switches. This guarantees mote's lifetime operations, while discarding replaceable AA batteries. (5) Finally, this paper proposes changes to mote's design to accommodate both float switch connectors, and in some cases external light sensors (particularly when distances between supports are widely spaced, which implies a single mote will not be able to monitor ambient light within deployed segment).

(6) Our research work prevents false positives since a crack in the outer HDPE pipe system implies either ongoing act of vandalism or a manufacturing defect. Either way, such cracks are quickly detected and reported. (7) Finally, this project utilizes wireless communication over wired communication [20][21][22] for two reasons (a) to maintain simplicity and (b) to reduce deployment and maintenance cost.

#### IV PROPOSED WORK

This paper recommends using wireless motes, light sensors and float switches to (1) sense ambient light, (2) respond to oil spills, and (3) report either pipeline damage or oil spills. Our earlier project [14] recommended using Mica2, Micaz and IRIS motes; however, in this paper, we propose a totally different kind of mote which we specifically designed for this project.

Our proposed mote will retain existing communication stack available in radio controllers used by Micaz and related products, the main difference between existing motes and our proposed mote are external connectors for light sensors and float switches.

As stated earlier, each mote will be powered from a central power bank, and where applicable, power banks will be repeated along pipeline deployment route.

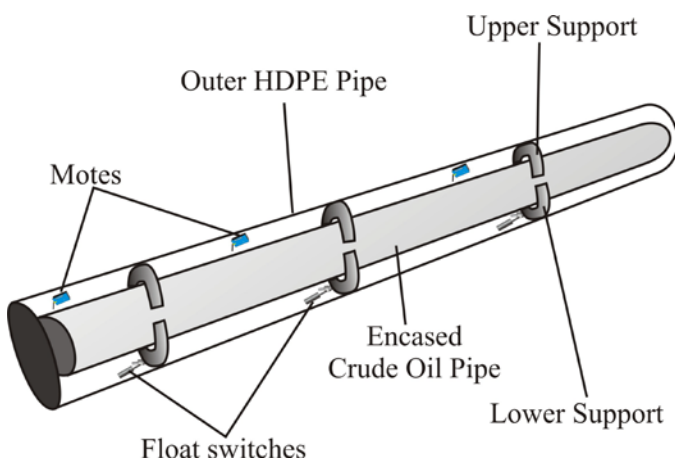

Figure 5. Side view of deployment plan, showing encased crude oil pipe

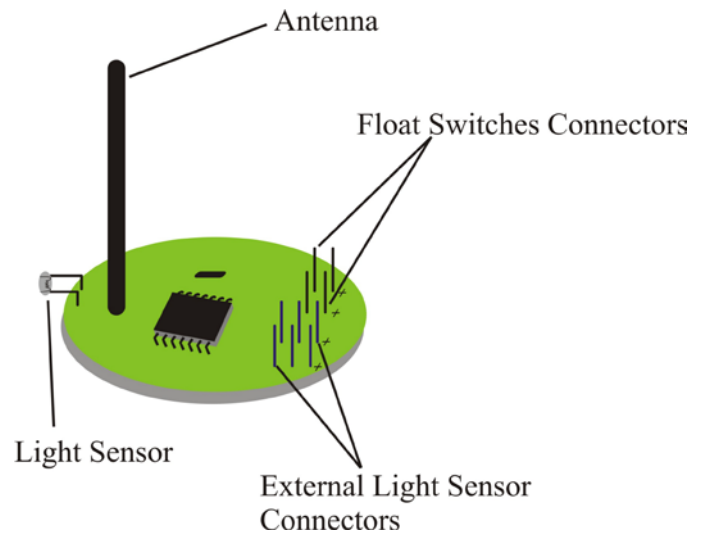

Figure 6. Propose mote design

In addition to the inbuilt light sensor, our proposed mote design accommodates two three-pin connectors for additional external light sensors and two two-pin connectors for float switches.

Sensors connected to the connectors trigger hardware interrupts each time ambience data is sensed, forcing the mote to suspend whatever it is doing and attend to the interrupt request.



Each interrupt request is queued and processed one at a time. This approach ensures race conditions do not arise, especially when float switches and light sensors send event signals at the same time.

While each mote will come with its light sensor, we recommend additional connectors for external light sensors, especially where distances between segments exceeds the capabilities of a single light sensor. Similar reasoning drives the adoption of a two two-pin connectors on our proposed mote, to allow two float switches within a segment.

A segment is the space between encased pipeline supports. These supports are designed to tightly fit around encased pipes, preventing both light and crude oil from other segments from filtering in. This ensures any mote reporting changes in ambient light will send its true location info to the base station, sending accurate location enable response teams to quickly pinpoint disaster area. However, each segment is designed to allow crude oil to flow into adjacent segments via an overflow hole. This prevents the oil from reaching and the motes.

A. Mote Location Identification

We propose assigning each mote a unique identification based on pipe section and deployment segment. For example, assuming a hundred HDPE smart pipes are used to encase crude oil pipeline from Warri to Sapele (towns in the Niger Delta region of Nigeria), the following identification will be employed.

**WS001001 - WS100500**

Where WS represents Warri to Sapele pipeline system, 001 to 100 represents each HDPE pipe section and 001 to 500 represents identification number for each mote/segment deployed along Warri – Sapele pipeline system.

The Gateway system responsible for processing reports from motes is installed with Oracle MySQL database server [17], the database table contains the following fields:

Table I. Propose MySQL database table layout

Field	Type/Length	Description
Recorded	Auto increment, Big Int, Primary Field	Record identification field
Moteid	Varchar(10)	Mote’s ID for example <b>WS001001</b>
Description	Varchar(255)	Describes each mote deployment information
Status	Varchar(12)	Sets mote’s status, with either “alive” or “unreachable”
Lastupdate	Datetime	Date and time when mote’s last pings Gateway
Motetype	Varchar(6)	Two values, either “Master” or “Backup”

The description field describes the location of each mote along pipeline deployment route. This approach eliminates any requirement for GPS sensors, while providing accurate location info for pipeline maintenance crew.

Enumerated below is a sample record for mote 001:

Table II. Sample record for mote 001

Recorded	1
Moteid	WS001001
Description	Warri Sapele pipeline system, Pipe Section 1, Segment 1. A KM from refinery east gate
Status	Unreachable
Lastupdate	2016-12-11 08:10:03
Motetype	Master

The Status field in Table 2 above is periodically updated by a stored procedure; this field can contain two values, namely *alive* or *unreachable*.

Lastupdate field is set whenever a mote contact the PAN Coordinator. Mote information is extracted from each mote’s source identification parameters [23] as encoded in the MAC Header.

Table III. Generic MAC Frame Format

Octets: 2	1	0/2	0/2/8	0/2	0/2/8	Variable	2
Frame Control	Sequence Number	Destination PAN ID	Destination Address	Source PAN ID	Source Address	Frame Payload	FCS
Addressing fields							
MHR						MPL	MFR

Abbreviations: FCS: Frame Check Sequence | MHR: MAC Header  
MPL: MAC Payload | MFR: MAC Footer

Both sensing motes and PAN Coordinator are programmed to periodically exchange awareness information during networks Contention Access Periods (CAP), or in response to beacon signal sent by PAN Coordinator.

As stated earlier, the stored procedure on the MySQL database runs a check on the table every 24 hours and updates the status field.

Motes that failed to communicate with the PAN Coordinator within each 24 hour window are marked as *unreachable* by the stored procedure’s SQL commands.

Reports generated by the Gateway enable maintenance crews to either activate segment backup mote or visit mote location to ascertain why it is unreachable.

Therefore, a suggested deployment scenario encourages placing two motes within a segment - a master mote and a backup/redundant mote. Redundant motes can be remotely programmed to assume sensing operation whenever the master mote breakdown or is unreachable. Remote instruction equally reprograms redundant mote with the identification of failed master mote.

Each redundant or backup motes share similar identification with their master mote; however, the letter B is appended to differentiate each on the network. For example, backup mote for a mote with identification WS001001 is WS001001B.

**B. Mote Message Forwarding**

Our proposed motes uses predictive multi-hop when forwarding messages from sender to receiver. For instance mote WS001001 will predicatively send messages to WS001002, which in turn will predicatively send messages to WS001003.

Our predictive multi-hop can be succinctly summarized as: *mote with identification x sends event messages to mote with identification x - 1.*

Predictive message forwarding ensures the channel is always clear to forward messages between sender and receiver. This is possible when motes are appropriately spaced, ensuring mote to mote hopping and not mote to multi-mote.

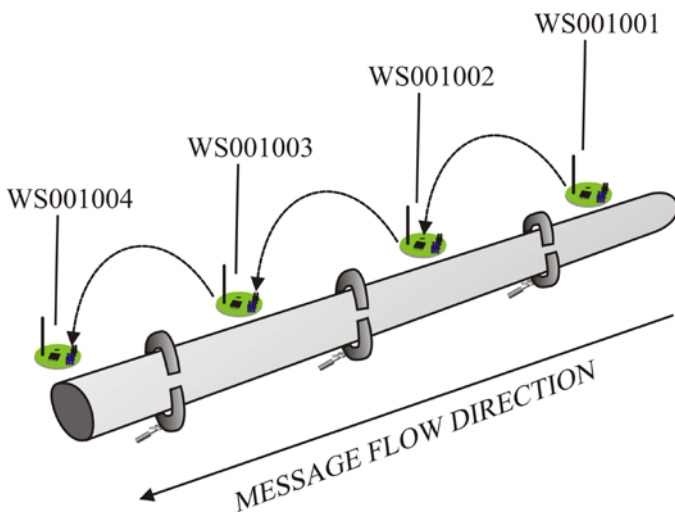

Figure 7. Predictive multi-hop

**C. Mote Security**

Motes are required to periodically communicate with their PAN Coordinator every 24 hours. Failure in communicating implies the mote is either lost to theft, or simply damaged.

**D. Mote/Gateway Messaging**

Proper messaging technique ensures hassle free operations amongst various technologies that make up our propose works. For example, mote status request is initiated by the central gateway to each cluster’s PAN, while pipeline related reports are initiated by monitoring motes upon positive feedback from attached sensors.

Message flow representation via process flowcharts are enumerated below.

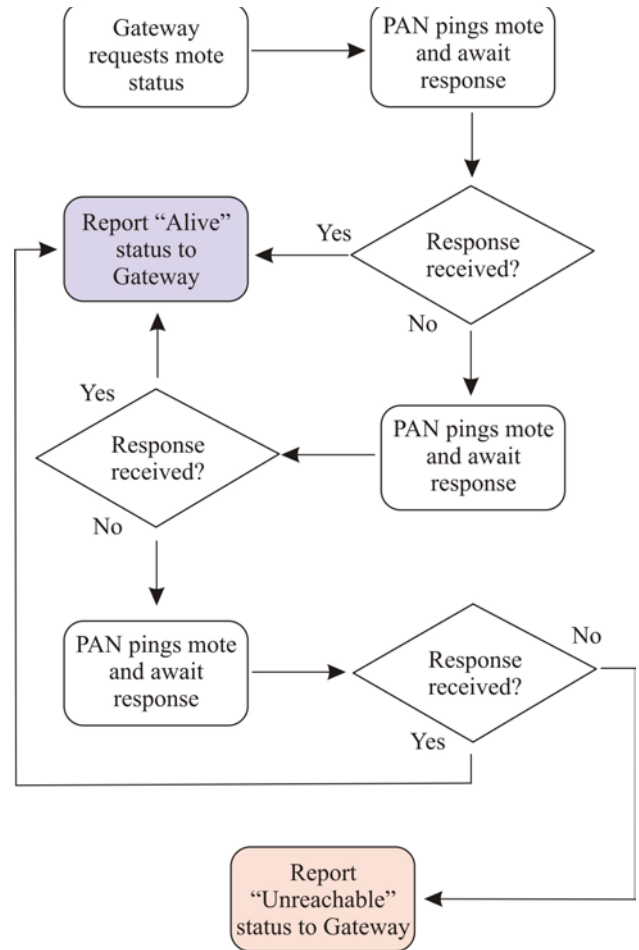

Figure 8. Gateway status request and response flowchart

The flowchart above depicts messaging process between gateway, PAN and mote. Cluster’s PAN reports “unreachable” only after failing to reach target mote after the third attempt. Response from PAN is used by the Gateway to update mote’s status.

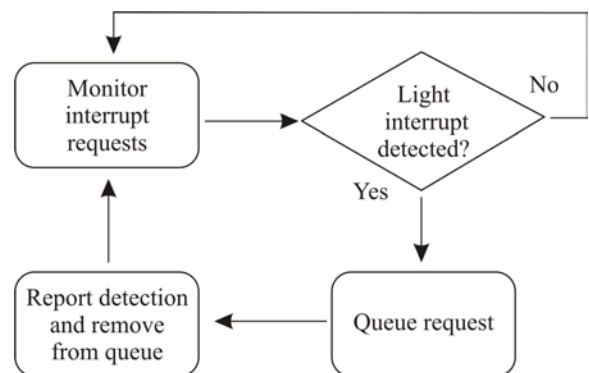

Figure 9. Light Sensor interrupt handling flowchart

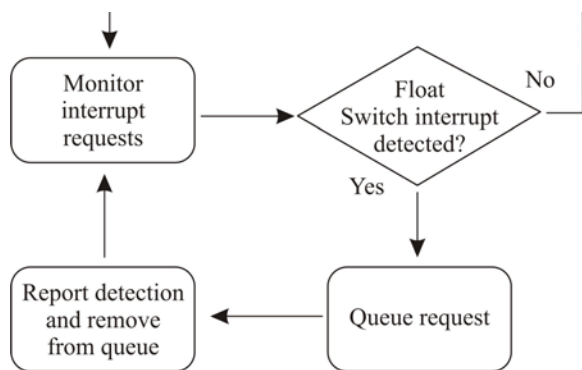

Figure 10. Float Switch interrupt handling flowchart

Figures 9 and 10 represent process flowcharts for handling detected events via interrupts. Interrupts requests are queued, processed (by reporting detected ambient event) and removed from queue.

#### D. Mote/Gateway Messaging

Proper messaging technique ensures hassle free operations amongst various technologies that make up our propose works. For example, mote status request is initiated by the central gateway to each cluster's PAN, while pipeline related reports are initiated by monitoring motes upon positive feedback from attached sensors.

#### E. Preventing Light Sensor False Positives

Like the Mica mote sensor boards MTS300 MTS310 our proposed sensor board uses a simple CdSe photocell, with a maximum light wavelength of 690 nm. The resistance of this photocell while exposed to light is 2 k $\Omega$ , while the off resistance, while in dark conditions is 520 k $\Omega$  [24].

Our design encapsulates the light sensor in a completely dark vacuum (the three-layered HDPE pipe completely encases the crude oil pipeline, while preventing any light from filtering in). Therefore, any light that filters in implies the protective outer HDPE pipe has been compromised, either through vandalism, weather conditions, manufacturing or installation flaw.

From the foregoing, false positives can be prevented by ensuring zero manufacturing defect and foolproof installation during deployment.

#### E. Preventing Float Switch False Positives

Our design position float switches at the bottom of the HDPE pipe. This design ensures any leakage from the encased crude oil pipeline collects at the bottom of the HDPE pipe. As soon as sufficient crude oil has collected at the bottom of the HDPE pipe, the float switch naturally snap shut, triggering the mote's overflow interrupt.

False positives can be prevented by the clean up crew, all they need do is ensure the float switch snaps back to the open

position after spilled crude oil has been drained from the HDPE pipe.

## V SIMULATION RESULT

Linear placement of motes within HDPE pipe sections constrains the project to adopt linear cluster. However, by adopting predictive multi-hop, we believe packet loss and collisions will either be minimized or completely eliminated from the personal area network.

Moreover, since power is provided from a external power bank, it is imperative to compute the final power consumption prior to deployment

To confirm our expectations, the following simulations were conducted using OPNET 14.5:

- Network Throughput
- End to end delay
- Number of hops
- Network Power Consumption

OPNET implements IEEE 802.15.4/ZigBee communication protocol using the following objects:

- ZigBee Coordinator
- ZigBee Station
- ZigBee Router
- ZigBee End-device

Each ZigBee object enumerated above can function as mobile or fixed devices. Since pipelines are fixed, we implemented our simulation using fixed ZigBee objects. Our simulation focused on the benefits of predictive hops over random hops within a linear cluster.

However, ZigBee End-devices cannot multi-hop from sender to receiver; rather they are designed to send their messages directly to their PAN ZigBee Coordinator, hence a ZigBee End-device that is not attached to a personal network ZigBee Coordinator automatically becomes an uninitialized network orphan. Therefore, this paper eventually discarded simulation results for Zigbee End-devices.

General simulation parameters are listed below:

- Simulation Time: 3000 s
- Packet Size: 1024
- Start Time: *Different Start Time*
- Packet Inter Arrival Time: Constant, Mean 1.0 s
- Scenario Size: 1000 x 1000 meters

#### A. Throughput Simulation Test Using Random Hops

This simulation examines the success rate of message delivery within the pipeline, using one ZigBee Coordinator with five ZigBee Routers:

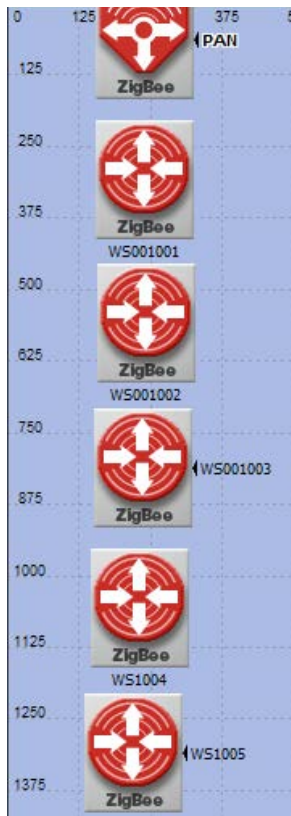

Figure 11. Layout of new simulation objects (ZigBee Coordinator and ZigBee Router) in OPNET Simulator

Parameters for each node are listed below:

<b>ZIGBEE COORDINATOR</b>		
1.	Name	PAN
2.	Network Type	Mesh
3.	Start Time	Uniform (20, 21)
<b>FIRST ZIGBEE ROUTER</b>		
1.	Name	WS001001
2.	Destination	PAN/Random
3.	Start Time	Uniform (180, 181)
<b>SECOND ZIGBEE ROUTER</b>		
1.	Name	WS001002
2.	Destination	PAN/Random
3.	Start Time	Uniform (150, 151)
<b>THIRD ZIGBEE ROUTER</b>		
1.	Name	WS001003
2.	Destination	PAN/Random
3.	Start Time	Uniform (120, 121)
<b>FOURTH ZIGBEE ROUTER</b>		
1.	Name	WS001004
2.	Destination	PAN/Random
3.	Start Time	Uniform (90, 91)
<b>FIFTH ZIGBEE ROUTER</b>		
1.	Name	WS001005
2.	Destination	PAN/Random
3.	Start Time	Uniform (60, 61)

The next set of simulation through results demonstrates the ability of nodes outside PAN coordinator coverage area to adopt multi-hop in delivery messages. We modified the Scenario size to 500 x 1500 meters to accommodate more nodes.

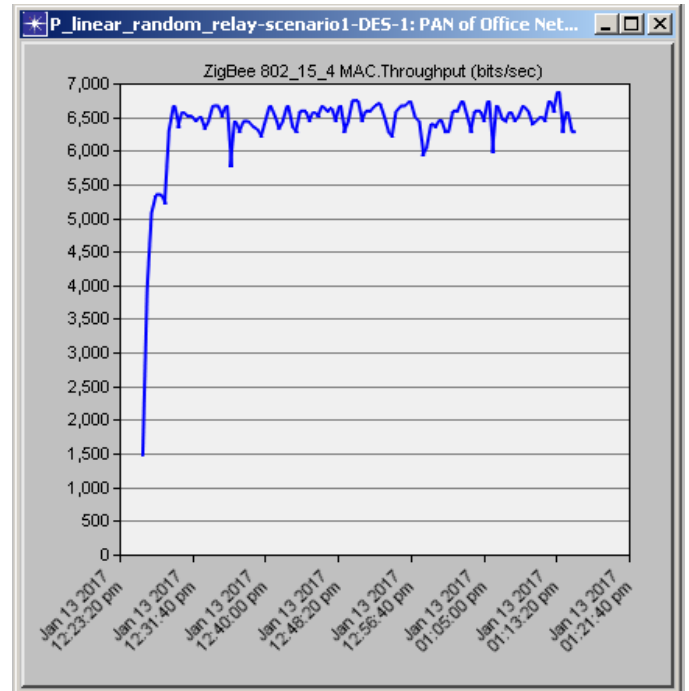

Figure 12. ZigBee PAN Throughput Simulation Result

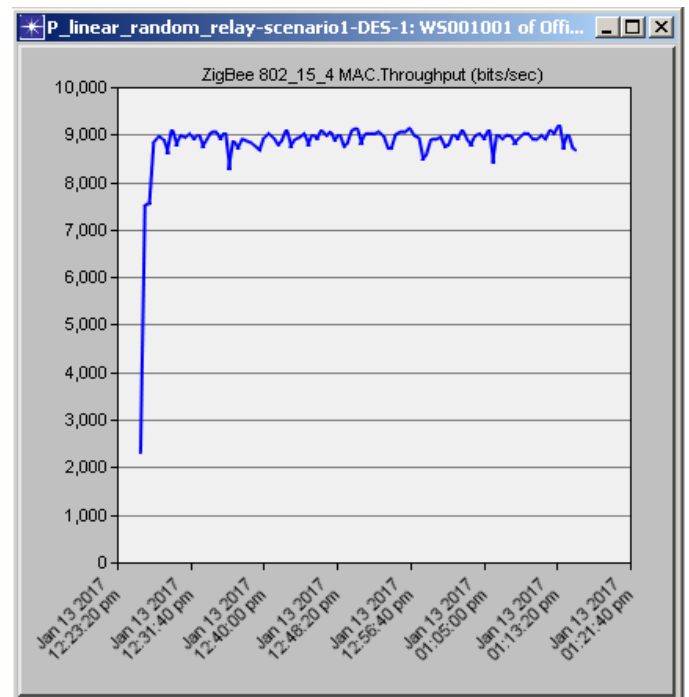

Figure 13. ZigBee Router (WS001001) Throughput Simulation Result



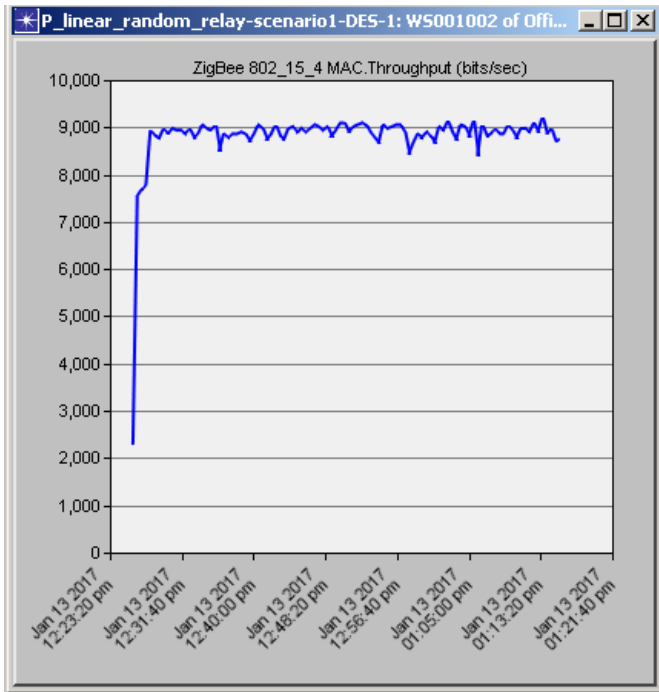

Figure 14. ZigBee Router (WS001002) Throughput Simulation Result

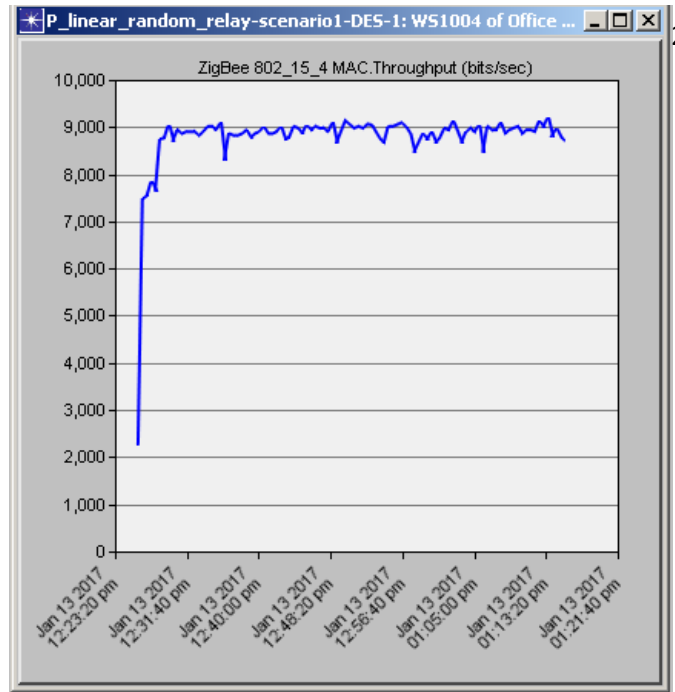

Figure 16. ZigBee Router (WS001004) Throughput Simulation Result

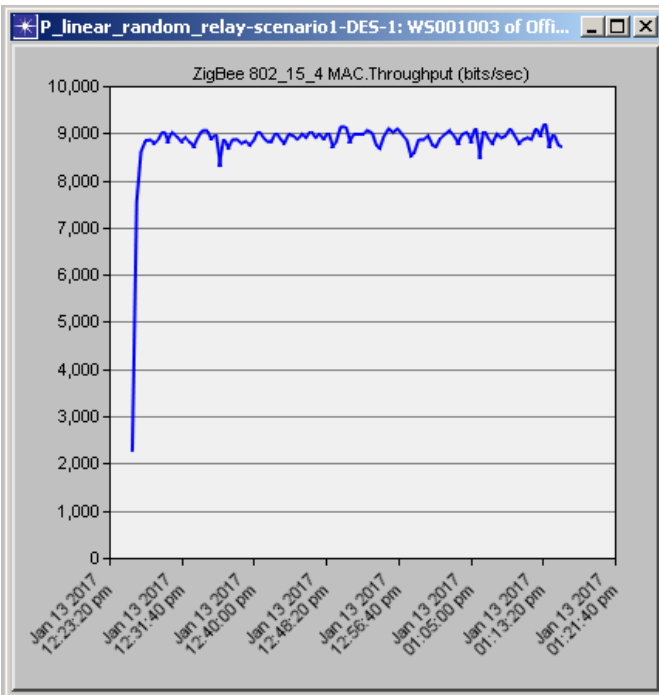

Figure 15. ZigBee Router (WS001003) Throughput Simulation Result

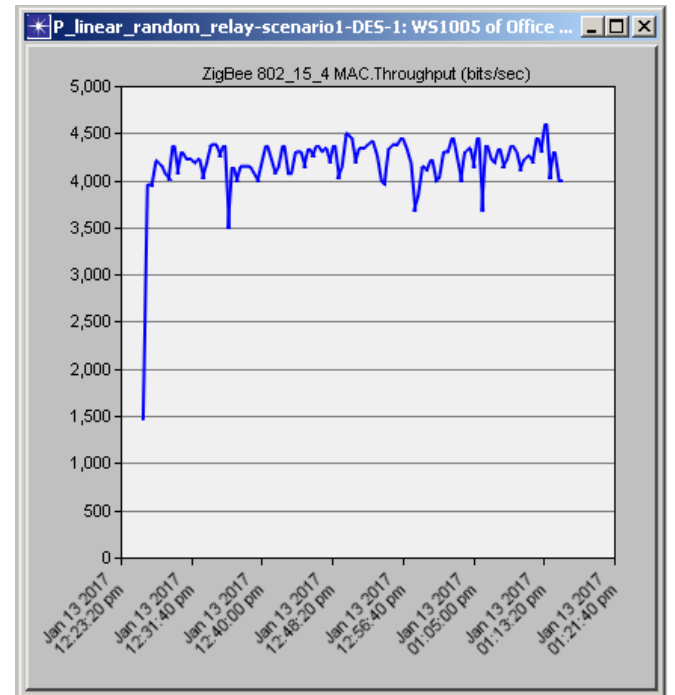

Figure 17. ZigBee Router (WS001005) Throughput Simulation Result

All five nodes were able to transmit data to their PAN Coordinator, including the last three nodes which were outside the PAN Coordinator's coverage area.

Implementing our simulation result in real life will reduce deployment costs through deployment of RFD (ZigBee End-devices) within PAN Coordinator's coverage area.

However, a FFD (ZigBee Router) will be deployed close to PAN Coordinator coverage boundary or perimeter. This placement allows nodes outside the coverage zone to route their requests through the borderline FFD.

**B. End to End Delay Simulation Results**

End to end delay simulation results displays the time it takes for transmitted packets from source node to reach destination node. Higher end to end delay results may indicate problems in the network deployment plan.

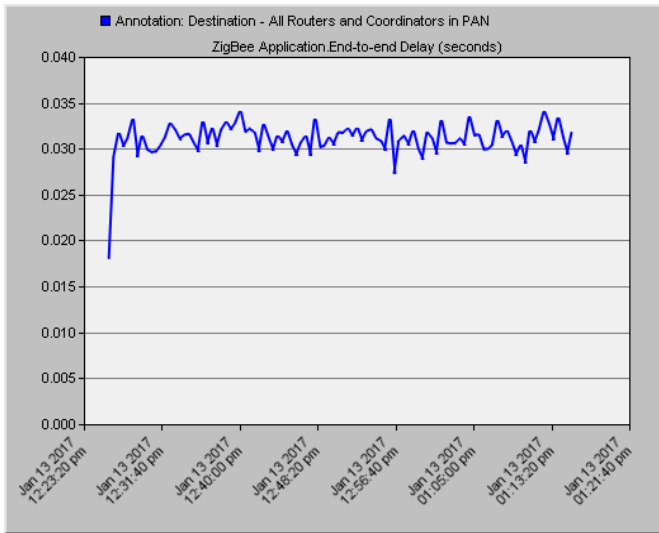

Figure 18. ZigBee Coordinator (PAN) End to End Simulation Result

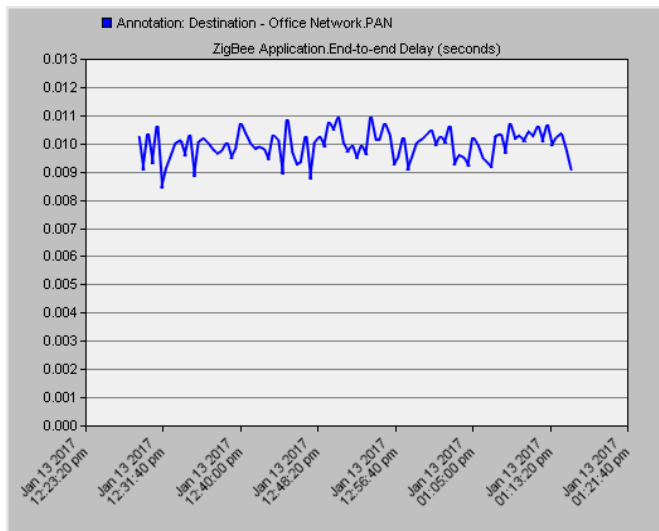

Figure 19. ZigBee Router (WS001001) End to End Simulation Result

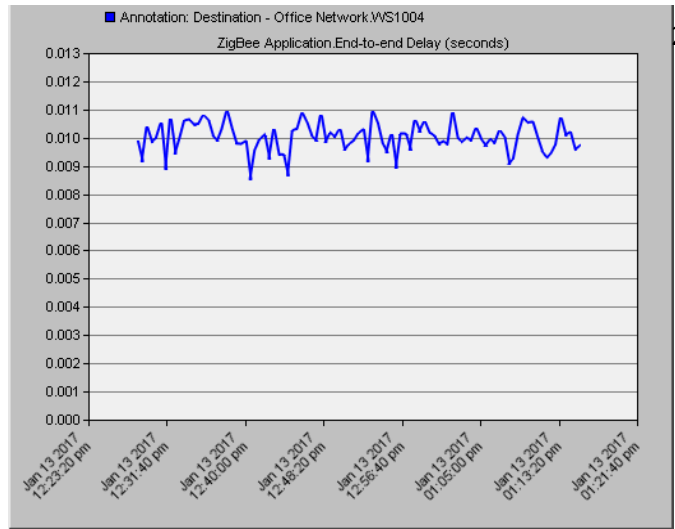

Figure 20. ZigBee Router (WS001002) End to End Simulation Result

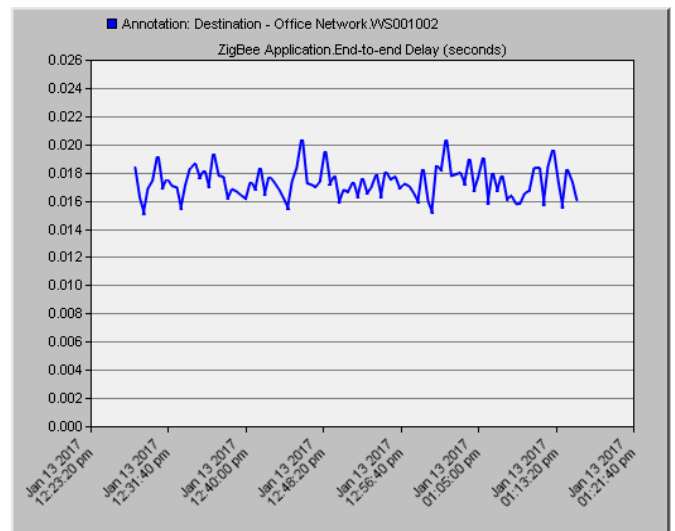

Figure 21. ZigBee Router (WS001003) End to End Simulation Result

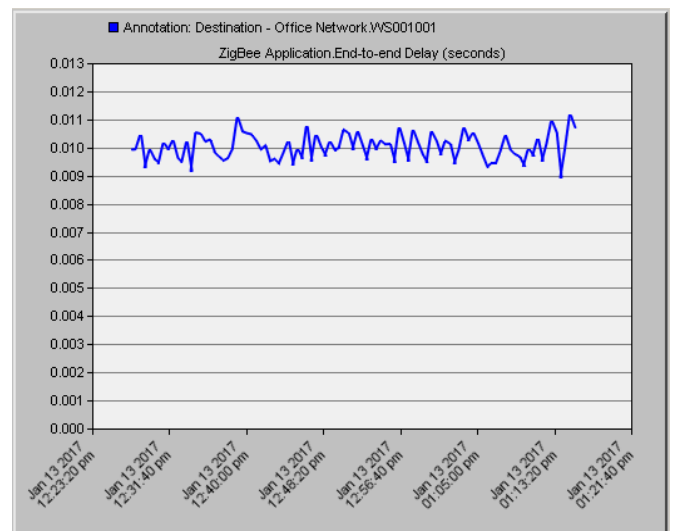

Figure 22. ZigBee Router (WS001004) End to End Simulation Result

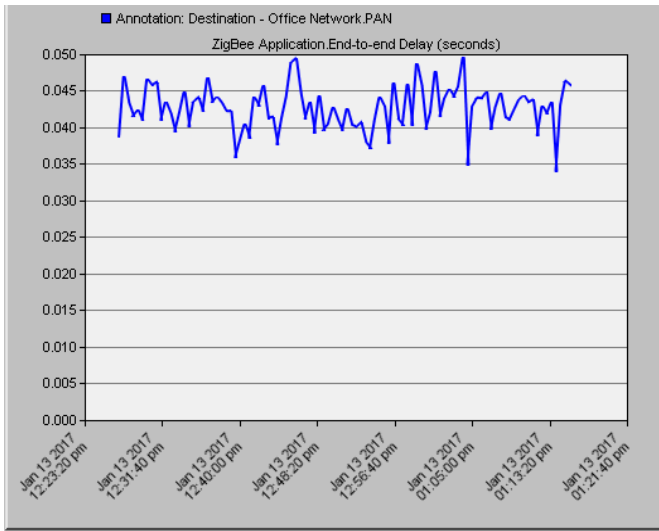

Figure 23. ZigBee Router (WS001005) End to End Simulation Result  
C. Number of Hops from Sender to Receiver

A hop represents a node in the path between source and destination nodes. Wireless sensors network data packets pass through nodes as they travel between source and destination. Each time packets are passed to the next node, a hop occurs. The hop count refers to the number of intermediary nodes through which data must pass between source and destination.

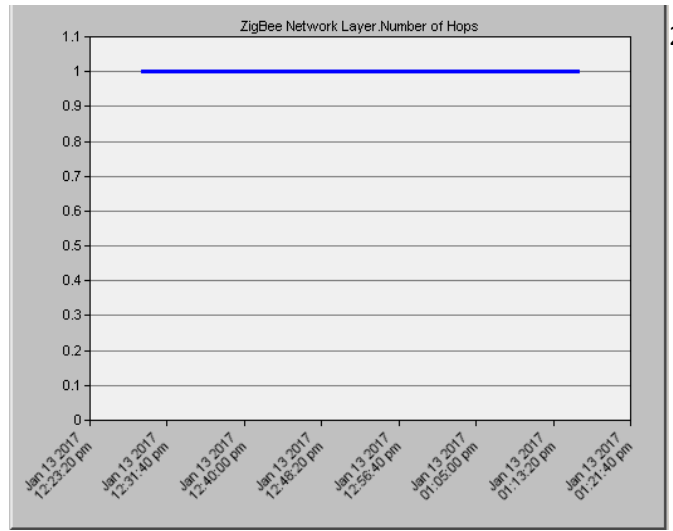

Figure 25. ZigBee Router (WS001001) Number of Hops Result

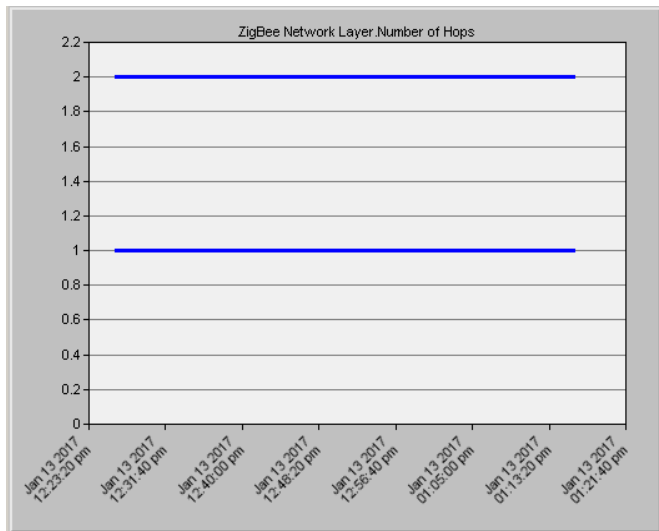

Figure 24. ZigBee Coordinator (PAN) Number of Hops Result

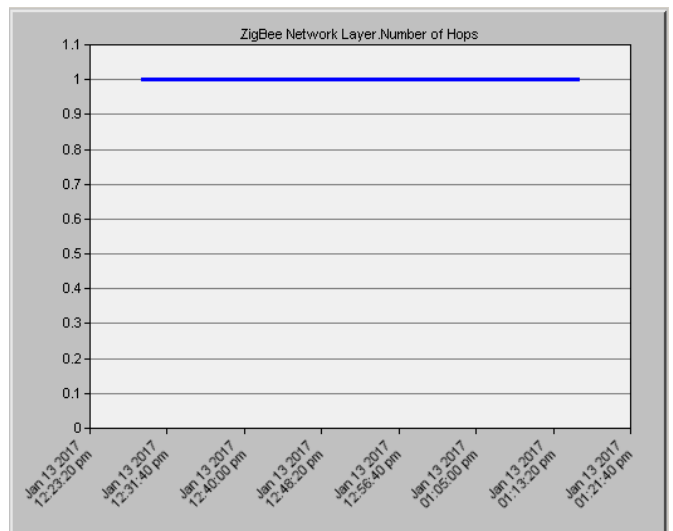

Figure 26. ZigBee Router (WS001002) Number of Hops Result

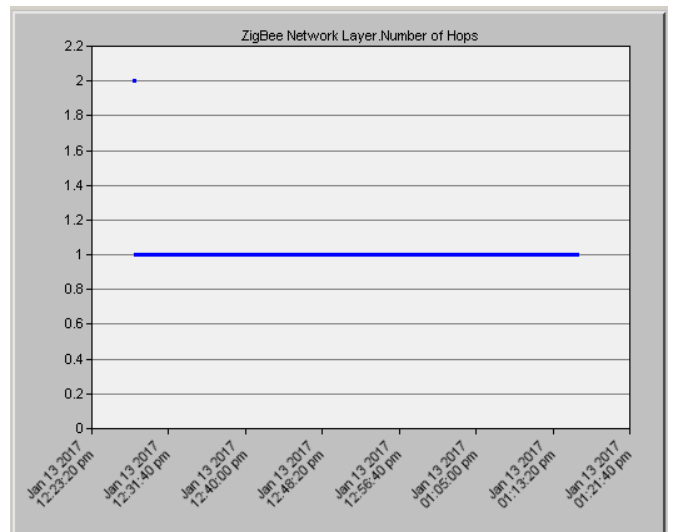

Figure 27. ZigBee Router (WS001003) End to End Simulation Result

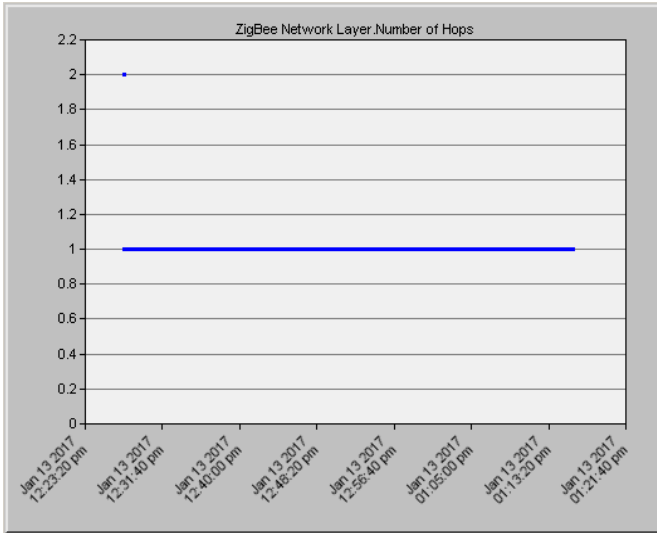

Figure 28. ZigBee Router (WS001004) End to End Simulation Result

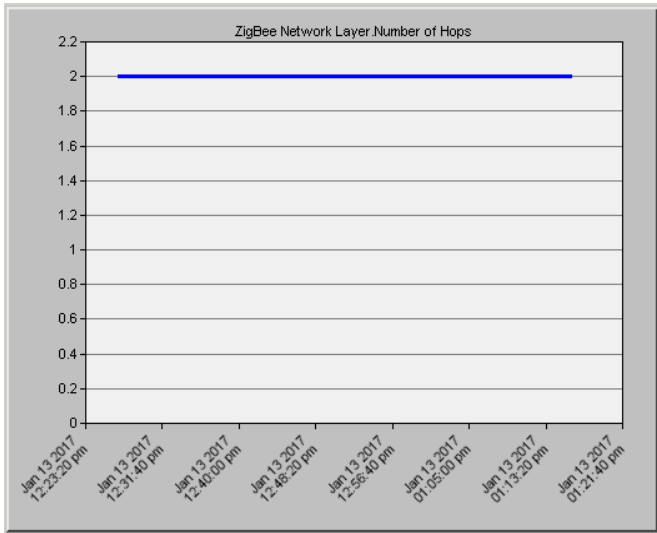

Figure 29. ZigBee Router (WS001005) End to End Simulation Result

We conducted the power consumption simulation using<sup>23</sup> OPNET 14.5, via Open-ZB IEEE 802.15.4/ZigBee OPNET Simulation Model [25]. Our simulation model consists of the following objects:

- 1 Network Analyzer
- 1 Node Coordinator
- 4 GTS-enabled End-devices

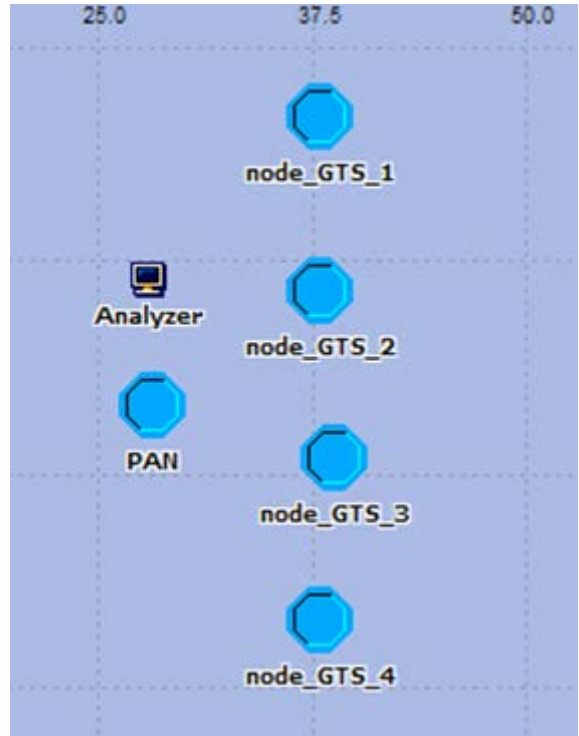

Figure 30. Layout of Open-ZB network Analyzer and Nodes

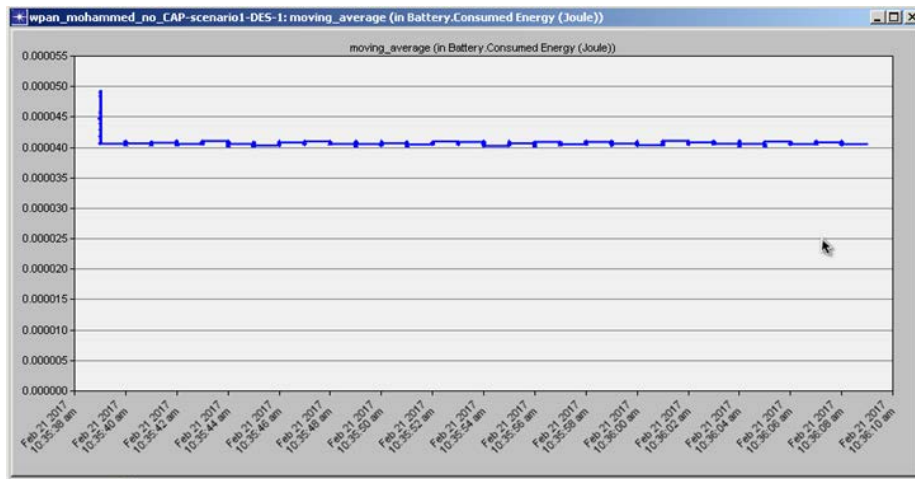

Figure 31. Battery Consumed (Energy) Graph



The energy consumption graph in Figure 31 reveals high energy consumption at the start of the simulation; however, this balances out as the simulation proceeds. This implies more energy is consumed when the network initializes and less is consumed when the network is fully operational.

## VI CONCLUSION AND FUTURE WORK

Messages between sender and receiver within a linear cluster depend on multiple hops, which is determined by the number of nodes between sender and receiver (as demonstrated by our simulation results).

Moreover, the advantages of predictive multi-hops within a pipe system is enormous, since it prevents nodes belonging to pipeline Segment A from communicating with Segment B or Z Coordinator, especially if such Coordinators are within range as a result of pipeline meandering downhill or around a bend.

Our future work is deployment of our proposal using live nodes specially manufactured to our requirements. We believe a successful deployment will create demand, giving rise to a thriving industry, especially in countries grappling with incessant oil spills. Finally, the environmental benefits of this project should reduce oppositions to crude oil pipeline construction along environmentally delicate routes.

## REFERENCES

- [1] M. Y. Agetegba and P. Lorenz "Using Sensor Technology to Monitor and Report Vandalized Pipelines" INNOV 2016: The Fifth International Conference on Communications, Computation, Networks and Technologies, August 2016, pp. 1 - 6
- [2] N. Bhavana, S. Anuradha, K. Sanjay, and P. Vinod "Energy Efficient MAC Protocols for Wireless Sensor Networks: A Survey" Computer Science and Engineering Survey Vol.2, No. 3, August 2011, pp. 122-129.
- [3] L. M. L. Oliveira and J. J. P. C. Rodrigues, "Wireless Sensor Networks: a Monitoring" Journal of Communications, April 2011, Vol. 6, No. 2, pp. 3-16.
- [4] L. M. L. Oliveira, J. J. P. C. Rodrigues, A. G. F. Elias, and B. B. Zarpelão, "Ubiquitous monitoring solution for Wireless Sensor Networks with push notifications and end-to-end connectivity" 2014 pp. 1 - 2.
- [5] G. Han, X. Jiang, A. Qian, J. J. P. C. Rodrigues, and L. Cheng, "A Wireless Comparative Study of Routing Protocols of Heterogeneous Sensor Networks" Research Article, June 2014, pp. 1-3.
- [6] E. Romero, A. Araujo, J. Blesa, and O. Nieto-Taladriz "Developing Cognitive Strategies for Reducing Energy Consumption in Wireless Sensor Networks" The Second International Conference on Advances in Cognitive Radio, COCORA 2012, pp. 64 – 65.
- [7] O. Diallo, J. J. P. C. Rodrigues, and M. Sene, "Real-time data Management on wireless sensor networks: A survey" Journal of Network and Computer Applications, [www.elsevier.com/locate/jnca](http://www.elsevier.com/locate/jnca) December 2011, pp.2 – 8.
- [8] V. N. G. J. Soares and J. J. P. C. Rodrigues, "Cooperation in DTN-Based Network Architectures" V2-05, April 2011, pp. 103 – 107.
- [9] K. Lin, J. J. P. C. Rodrigues, H. Ge, Naixue Xiong, and X. Liang "Energy Efficiency QoS Assurance Routing in Wireless Multimedia Sensor Networks", IEEE Systems Journal, Vol. 5, December 2011 pp.1-3.
- [10] Mehdi Yari. "The 6 Corrosive Components That Can Be Found in Crude Oil" Corrosionpedia, August 21, 2015. <https://www.corrosionpedia.com/2/1424/corrosion/the-6-corrosive-components-that-can-be-found-in-crude-oil>
- [11] Tests confirm polyethylene pipe for high-pressure oil, gas service. <http://www.oilandgas.com/articles/print/volume-94/issue-37/in-this-issue/general-interest/tests-confirm-polyethylene-pipe-for-high-pressure-oil-gas-service.html>. Oil and Gas Journal, 1996
- [12] S. A. Ahlam and A. Manal "Medium Access Control Protocols for Wireless Sensor Networks Classifications and Cross-Layering" Science Direct, Procedure Computer Science, [www.Sciencedirect.com](http://www.sciencedirect.com), ICCMIT, 2015, pp. 2-13.
- [13] A. M. Sadeghion, N. Metje, D. N. Chapman, and C. J. Anthony "Smartpipes: Smart Wireless Sensor Networks for Leak Detection In Water Pipelines" Journal of Sensor and Actuator Networks, February 2014, pp. 1-15.
- [14] L. Luo, Q. Cao, C. Huang, T. Abdelzaher, John A. Stankovic, and M. Ward, "EnviroMic: Toward Cooperative Storage and Retrieval in Audio Sensor Networks", 2009, pp. 1- 22
- [15] J. Kim, G. Sharma, N. Boudriga, and S. S. Iyengar "SPAMMS: A Sensor-based Pipeline Autonomous Monitoring and Maintenance System" IEEE Explore, 2010, pp.2-11.
- [16] M. Alnuem "Performance Analysis of Node Placement in Linear Wireless Sensor Networks" Journal of Emerging Trends in Computing and Information Sciences, January 2014, Vol. 5, No. 1, pp.1 – 8
- [17] M. F. F. Bin Ismail and Wai Yie "Acoustic Monitoring System Using Wireless Sensor Networks" International Symposium on Robotics and Intelligent Sensors, 2012, pp. 2-7.
- [18] C. Pandeewaran, N. Pappa, and S.G. Jayesh "Hybrid MAC Protocol for Wireless Sensor Networks used in Time Critical Applications" Computer Science and Information Technology, 2014, pp. 3- 9.
- [19] M. Lujuan, L. Henry, and L. Deshi "Hybrid TDMA/CDMA MAC Protocol for Wireless Sensor Networks" Journal of Network, Vol. 9, No.10, October 2014, pp. 2665 – 2673.
- [20] Aubrey Kagan "Combining power and data wires, Part 1". May, 2015 <http://www.embedded.com/electronics-blogs/without-a-paddle/4439353/Combining-power-and-data-wires--Part-1>
- [21] Paul Pickering "Power & Signal Over A Single Wire Do More With Less". May, 2015. [http://www.eetimes.com/author.asp?section\\_id=36&doc\\_id=1326167&](http://www.eetimes.com/author.asp?section_id=36&doc_id=1326167&)
- [22] Wikipedia "Highway Addressable Remote Transducer Protocol" [https://en.wikipedia.org/wiki/Highway\\_Addressable\\_Remote\\_Transducer\\_Protocol](https://en.wikipedia.org/wiki/Highway_Addressable_Remote_Transducer_Protocol)
- [23] RF Wireless World "Zigbee MAC layer frames". 2012. <http://www.rfwireless-world.com/Tutorials/Zigbee-MAC-layer-frame-format.html>
- [24] Crossbow Technologies "MTS/MDA Sensor Board Users Manual Revision B, June 2006"
- [25] Petr Jurcik Open-ZB IEEE 802.15.4/ZigBee OPNET Simulation Model. [http://www.open-zb.net/wpan\\_simulator.php](http://www.open-zb.net/wpan_simulator.php)