

# Design of Highly Selective Band Pass Filter with Wide Stop-band using Open Stubs and Spurlines for Satellite Communication (SATCOM) Applications

Nitin Muchhal<sup>1</sup>, Mostafa Elkhoully<sup>1</sup>, Kurt Blau<sup>2</sup>, Shweta Srivastava<sup>3</sup>

<sup>1</sup> Fraunhofer Institute for Integrated Circuits IIS, Am Wolfsmantel 33, 91058 Erlangen, Germany  
{firstname.lastname@iis.fraunhofer.de}

<sup>2</sup> Technische Universität Ilmenau, P.O.B. 100565, D-98684 Ilmenau, Germany  
{firstname.lastname@tu-ilmenau.de}

<sup>3</sup>Jaypee Institute of Information Technology, Noida 201309, India  
{firstname.lastname@jiit.ac.in}

**Abstract** - A miniaturized selective composite microstrip Band Pass Filter (BPF) with a 3-dB fractional bandwidth of 52.5% (14.2 GHz to 24.5 GHz) with wide upper stop-band for satellite communication (SATCOM) application is proposed. The design consists of a composite BPF implanted with a pair of quarter-wavelength open-circuited stub and spurline. These elements are combined to form a miniaturized filter with a compact occupied area of  $0.72\lambda_g \times 0.55\lambda_g$  ( $\approx 0.26 \text{ cm}^2$ ). The filter is simulated on 0.008" (0.203 mm) Rogers 4003C with dielectric constant,  $\epsilon_r=3.55$  using commercial full-wave electromagnetic simulator HFSS v16. Simulated results show that BPF has resonant frequency ( $f_0$ ) as 14.2 GHz and wide ( $>3f_0$ ) stop band without increasing the circuit size. Further, Spurline behaves as notch filter to suppress the first harmonics (or second pass band) of the proposed BPF.

**Keywords**- Composite BPF; Open Stub; Spurline; Harmonic Suppression; SATCOM

## I. INTRODUCTION

Band Pass Filters (BPFs) have found numerous applications in satellite communication and play a vital role in several microwave and Radio Frequency (RF) applications. A high filtering performance, compact size, wide bandwidth, low insertion loss, wide upper stop-band and low cost are amongst the desired criteria while designing a band-pass filter [1]. In recent time, a significant amount of research work has been going on to design a compact BPF with high selectivity and good stop band performance for Ku/K band applications. Due to scarcity of the bandwidth in lower bands and availability in higher bands, the Ku/K band has become very popular for various satellite communication (SATCOM) applications [2].

Significant studies have been done over the past few years on the design of wideband band pass filters for Ku/K frequency bands using microstrip and Substrate Integrated Waveguide (SIW) [3] technology. Xu et al. [4] projected a Ku band BPF using folded feedlines and quarter-wavelength stepped-impedance resonators to generate multiple coupling paths. Lin et al. [5] proposed a compact novel K band BPF based on

Photonic Band Gap (PBG) structure. Owing to its slow-wave characteristics, the PBG structure reduces the filter size to one-tenth of conventional filters with spurious free response and deep attenuation level. The filter design cascaded several PBG structures introducing a coupling gap. Recently, Navya et al. [6] proposed the design of a low-profile and broad band BPF for Ku band satellite applications which consisted of four  $\lambda/4$  transmission lines and two feed lines to connect the resonating lines. In addition, selective band-pass filters for Ku and K bands have been reported by [7] using folded SIW technology incorporating E shape slot in the middle septum. Also, a wideband band-pass filter for Ku band was proposed by [8] using multi-mode resonator Substrate Integrated Waveguide (SIW) technology. Nonetheless, these filters suffered from fabrication complexity due to metallic vias. Further, stop-band response was not very satisfactory. In the past, various researchers have proposed band pass filters, but either the design was quite complex with large size or it suffered from poor selectivity or poor stop band. The present work utilizes the expediency of open stubs and spurline with a composite band pass filter for realizing miniaturized selective band pass filter with wide stop-band. Also, the proposed filter is very easy to fabricate. The designs are simulated using electromagnetic (EM) simulator High Frequency Structure Simulation (HFSS) v.16 software [9].

Section I explains the introduction and literature review. The rest of the paper is structured as follows. Section II explains the design of the composite band-pass filter by combining a low pass and high pass filter. Section III shows the effect of adding open stub on the composite band pass filter for better selectivity. Section IV discusses the effect of adding spurlines for enhancing stop band performance and, finally, Section V presents the conclusion of the proposed work.

## II. DESIGN OF THE COMPOSITE BAND PASS FILTER

A wideband BPF can be designed by cascade of a Low Pass Filter (LPF) and a High Pass Filter (HPF) [10], as shown in Figure 1. In this contribution, a stepped impedance structure has been used to design the LPF section as it occupies less area. The function of stepped impedance LPF is to attenuate the second pass-band (harmonics) in the upper stop-band. For attaining the high-pass characteristic, quarter-wave long short-circuited stubs are tapped to the high-impedance sections of the low-pass filter to insert attenuation poles at DC. The objective of the proposed band pass filter is to achieve high selectivity and roll off rate.

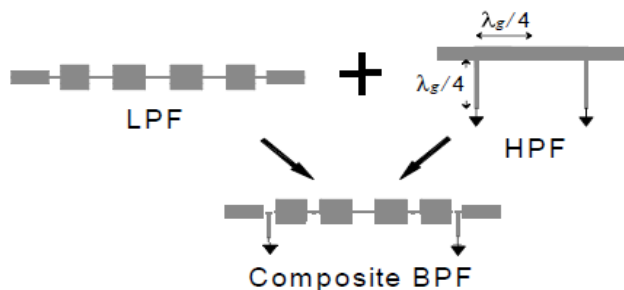

Figure 1. Development of the proposed composite BPF

### A. Design of Maximally Flat (Butterworth) Low Pass Filter (LPF)

A butterworth filter has advantage of having more linear phase response in the pass-band thereby able to provide better group delay performance. The column 2 gives element value (g)[10] for maximally flat LPF for N=5. The width and lengths of hi –low impedance sections for maximally flat Low Pass filter (LPF) with cutoff frequency ( $f_c$ ) = 24 GHz, Filter order (N) = 5, substrate RT Roger 4003 ( $\epsilon_r$  = 3.55) and substrate height (h) = 0.203 mm is calculated using [11] and is given below in table 1. We have considered  $Z_l$  (low impedance value) = 20  $\Omega$ ,  $Z_h$  (high impedance value) =120  $\Omega$ , and characteristic impedance,  $R_o=50 \Omega$ . The electrical length ( $\beta l$ ) for C is found using expression  $\frac{C}{R_o} \times Z_l$  and for L, it is given as  $\frac{L}{Z_h} \times R_o$ . The overall dimensions of LPF are: Length, L = 4.4 mm and Width, W = 4.0 mm.

TABLE 1. TABLE TO CALCULATE DIMENSIONS OF LPF

S. No.	Element Value (g)	Z( $\Omega$ )	$\beta l$ (in degree)	L (length in mm)	W (width in mm)
1	$g_1 = 0.5176$ (C1)	20	11.86	$L_2 = 0.25$	$W_2 = 1.96$
2	$g_2 = 1.618$ (L2)	120	38.63	$L_3 = 0.85$	$W_3 = 0.085$
3	$g_3 = 2.0$ (C3)	20	45.86	$L_4 = 0.92$	$W_4 = 1.96$
4	$g_4 = 1.618$ (L4)	120	38.63	$L_3 = 0.85$	$W_3 = 0.085$
5	$g_5 = 0.618$ (C5)	20	14.17	$L_2 = 0.28$	$W_2 = 1.96$
6	$g_6 = 1.0$	50	50	$L_1 = 0.60$	$W_1 = 0.55$

Figure 2 depicts the structure of LPF with calculated dimension.

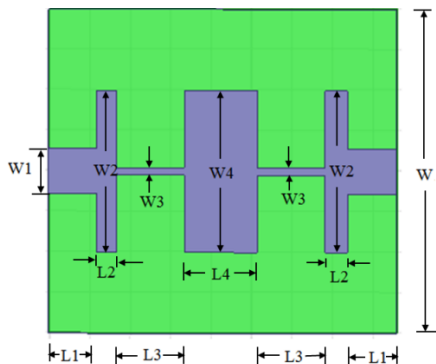

Figure 2. Stepped Impedance Low pass filter

Figure 3 shows the frequency response of LPF. From the graph, it is clear that the LPF possess cutoff frequency of 24 GHz.

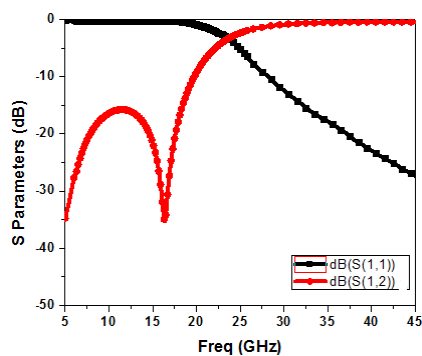

Figure 3. Frequency response of Low pass filter

**B. Shorted Stub as High Pass Filter (HPF)**

To realize the lower frequency stop-band, quarter-wave short circuited stubs are used with metallic via at the open end of the stub which acts as HPF section of the composite BPF. The length of shorted stub is  $\lambda_g/4$  ( $\lambda_g$  : guided wavelength) which turns out to be 1.8 mm for lower cutoff frequency ( $f_1$ ).

**C. Design of Composite Band Pass Filter**

To design a composite band pass filter, a High Pass Filtering (HPF) section need to be combined with Low Pass Filtering (LPF) section. The quarter wavelength ( $\lambda_g/4$ ) long short circuited stubs act as HPF. After examining various orientations of shorted stubs, it was found that the shorted stubs placed in alternating positions as shown in Figure 4, gave satisfactory

response. The value of various design parameters are as follows: diameter (D) =0.25 mm, width (W5) = 0.5 mm and length (L5) = 2.6 mm. The overall dimension of the filter is 6 mm x 4.4 mm.

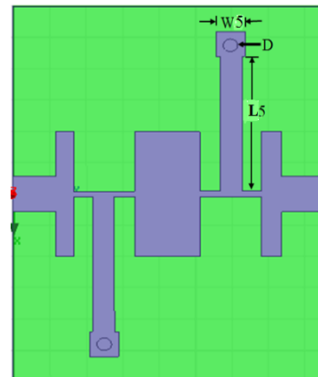

Figure 4. Composite Band-pass filter

Figure 5 depicts the frequency response of the composite BPF. From graph it can be seen that the filter center frequency ( $f_0$ ) is 18.5 GHz with % Fractional Bandwidth (FBW) of 48%. Further, there appears first harmonic placed near  $2f_0$  in the stop band which results in poor stopband performance. Also, the selectivity of the filter is quite poor.

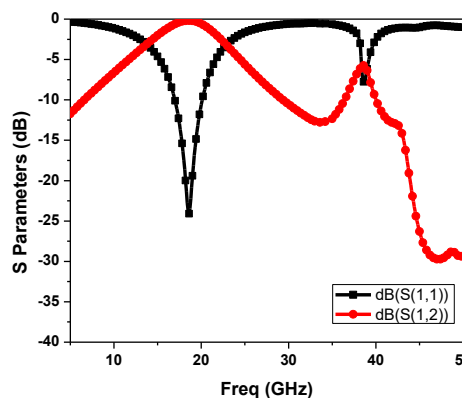

Figure 5. Frequency response of Composite Band-pass Filter

**III. COMPOSITE BAND PASS FILTER INTEGRATED WITH OPEN STUBS**

To improve the stop band performance and enhance the selectivity of the proposed elliptic filter, open stubs of length  $\lambda_g/4$  are placed opposite to the shorted stubs, as shown in Figure 6.

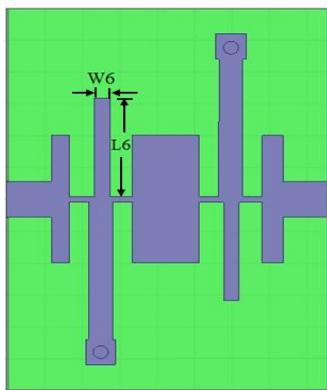

Figure 6. Band-pass Filter with open stubs

To generate a band notch in an Ultra-Wide Band (UWB) BPF, Shaman et al. [12] has proposed the concept of embedded open-circuit stub. The notch effect occurs when the length of open stub is quarter wavelength long [13]. The resonant behavior of  $\lambda_g/4$  open-stub can be explained by the equivalent circuit as shown in Figure 7.

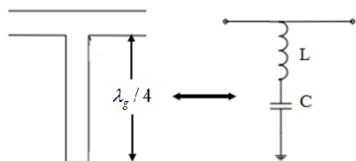

Figure 7. Equivalent circuit of open stub

From the transmission line theory, input impedance for the open-stub is given as:

$$Z_{in} = -jZ_0 \cot \beta l \quad (1)$$

From (1), the impedance of open-sub is low at integer multiple ( $n \lambda_g/4$ ) of resonant frequency thus achieving band-stop or notch characteristics. Also, open stub introduces one Transmission Zero (TZ) augmenting the selectivity of the filter by suppressing the undesired harmonic [14]. The length of the open stub to suppress first spurious responses (located near twice of the fundamental frequency) is calculated to be:  $L_6=1.55$  mm. The width  $W_6$  is kept at 0.30 mm. Figure 8 depicts the frequency response of composite BPF embedded with open stubs. From the curve, it is apparent that the center frequency ( $f_0$ ) of the band pass filter is 19.6 GHz with FBW calculated to be 54.6%.

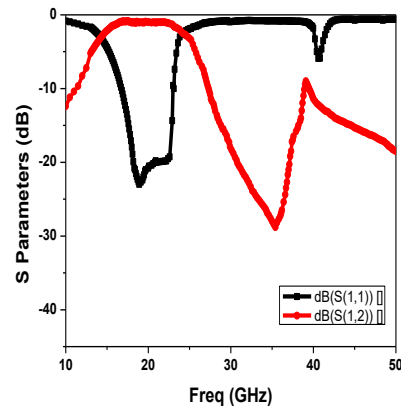

Figure 8. Frequency response of band pass filter with open stubs

Also it is evident from frequency response that the first harmonic (near  $2f_0$ ) is suppressed up to -10 dB with the addition of open stubs, but still stop band performance is not satisfactory.

#### IV. COMPOSITE BAND PASS FILTER INTEGRATED WITH OPEN STUBS AND SPURLINE

Generally, by cascading additional open stubs into microstrip filter, a wider and a deeper rejection can be achieved. The drawback of this method is high insertion loss in the passband and increased circuit size. A spurline is realized by etching L shape slot on microstrip line exhibiting band-stop (notch) characteristics and also used for further suppressing the harmonics [15][16]. The spur-line filter consists of coupling between two microstrip lines. Figure 9 shows a spur-line filter configuration. Here, 'A' is the length of the spur-line and B is width of the microstrip line.

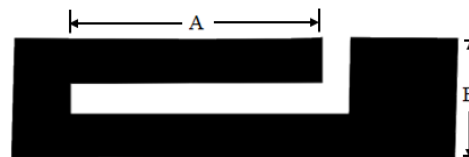

Figure 9. Structure of spurline

Figure 10 shows the structure of the proposed band pass filter incorporating open stubs and spurline. All the dimensions in this layout have been mentioned earlier.

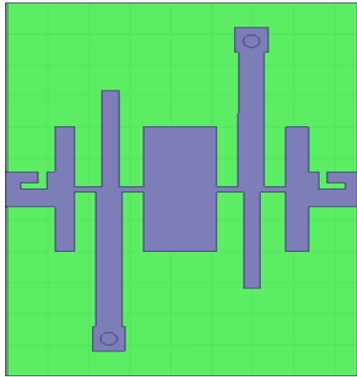

Figure 10. Band pass filter with open stub and spurline

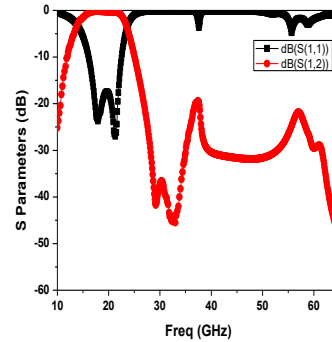

Figure 12. Frequency response of band pass filter with open stub and spurline

Figure 11 shows the parametric analysis of spurline for various lengths. The length of spurline ( $A$ ) is calculated by using parametric analysis and it is found that first harmonic ( $f_0 = 38.5$  GHz) is well suppressed below  $-20$  dB for spurline length ( $A$ ) equal to  $0.75$  mm.

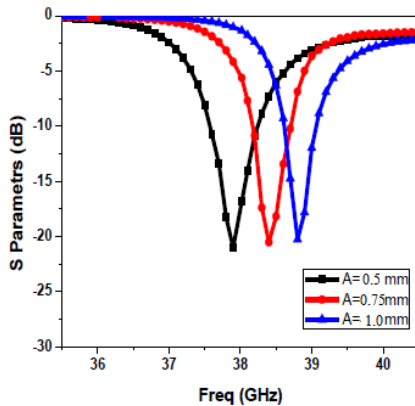

Figure 11. Parametric analysis of spurline for various lengths

Figure 12 shows the frequency response of final proposed band pass filter with open stubs and spurline. It is evident from the response that filter has pass-band from  $14.2$  GHz to  $24.5$  GHz with center frequency ( $f_0$ ) at  $19.2$  GHz and % FBW calculated to be  $52.5\%$ . As can be seen from Figure 12, that additional attenuation is achieved at the first harmonic frequency by the incorporation of the spur line without increasing the circuit size. The harmonic at  $38.5$  GHz ( $2f_0$ ) is suppressed from  $-10$  dB to  $-22$  dB with the spurline band-stop filter (BSF).

Hence, an improvement in suppression of  $12$  dB is achieved and out-of-band rejection level is  $\geq 20$  dB.

## V. CONCLUSION

In this paper, a microstrip composite BPF is proposed and simulated using shunt open stubs and spurlines. Basically, open-stub section helps in achieving a wide rejection bandwidth. Further, Spurline with its inherently compact characteristics is inserted on input/output feed-lines that introduce attenuation pole to further suppress the higher harmonic mode resulting in better rejection performance without increasing the size. The proposed filter has merit of compact size with good filtering properties and can be useful for various SATCOM applications.

## ACKNOWLEDGEMENT

This work was carried out during the tenure of an ‘ERCIM (The European Research Consortium for Informatics and Mathematics) Alain Bensoussan Fellowship’ programme. Founded in 1988, ERCIM has members from leading European information technology and mathematics research establishments from 18 countries with head office in France.

## REFERENCES

- [1] J. S. Hong and, M.J. Lancaster “Microstrip Filters for RF/Microwave Applications”, 2nd Edition, John Wiley & Sons Ltd, 2011.
- [2] M. A Elkhoully et al., “Standardized testing conditions for satellite communications on-the-move (SOTM) terminals”, International Journal of Satellite Communications and Networking, vol 37 3, pp 163-182, June 2019.
- [3] N. Muchhal and S. Srivastava, "Review of recent trends on miniaturization of substrate integrated waveguide (SIW) components," 3rd International Conference on Computational Intelligence & Communication Technology (CICT), India, 2017, pp. 1-6.
- [4] X. Hong, H. Zhang and H. Tang, "Compact Bandpass Filter with Multiple Coupling Paths in Limited Space for Ku-Band Application," in IEEE Microwave and Wireless Components Letters, vol. 27, no. 3, pp. 251-253, March 2017.
- [5] L. Haili, M. Junfa and L. Jianyu, “A Novel compact K band PBG microstrip structure band-pass filter”, International Journal of Electronics, vol. 92, pp. 467-471, 2005.

- [6] A. Navya, G. Immadi, and V. N. Madhavareddy, "A Low-Profile Wideband BPF for Ku Band Applications," *Progress in Electromagnetics Research Letters*, vol. 100, pp. 127-135, 2021.
- [7] N. Muchhal, A. Chakraborty, V. Manoj, and S. Srivastava, "Slotted Folded Substrate Integrated Waveguide Band Pass Filter with Enhanced Bandwidth for Ku/K Band Applications", *Progress in Electromagnetics Research-M*, vol. 70, pp. 51-60, 2018.
- [8] N. Muchhal and S. Srivastava, "Design of Compact and Wideband Comb shape SIW Multimode Resonator Band Pass filter", *International Journal of RF and Microwave Computer-Aided Engineering*, vol 29 (9), pp. 1-9, April 2019.
- [9] User Manual Ansys Inc. High frequency structure simulator (HFSS) software ver. 16.
- [10] C. L. Hsu, H. Fu, and J. K. Kuo, "Microstrip bandpass filters for Ultra-Wideband (UWB) wireless communications," *IEEE MTT-S International Microwave Symposium Digest*, CA, USA, 2005, pp. 679-682
- [11] G. L. Matthaei, L. Young, and E. M. T. Jones, "Microwave Filters, Impedance-Matching Networks, and Coupling Structures", Artech House, Dedham, Mass., 1980.
- [12] H. Shaman and J. S. Hong., "Ultra-Wideband (UWB) Bandpass Filter with Embedded Band Notch Structures," in *IEEE Microwave and Wireless Components Letters*, vol. 17, no. 3, pp. 193-195, March 2007.
- [13] S. Yang, "A compact dual-band bandstop filter having one spurline and two embedded open stubs", *Journal of Electrical Systems and Information Technology (Elsevier)*, vol. 3(2), pp. 314-319, Sept 2016.
- [14] A. I Harikrishnan., S. Mridula and P. Mohanan, "Stub loaded hexagonal open loop band pass filter with improved selectivity," 2019 *URSI Asia-Pacific Radio Science Conference (AP-RASC)*, N. Delhi 2019, pp. 1-4.
- [15] R. N. Bates, "Design of microstrip spurline band-stop filters", *IEE Journal on Microwaves, Optics and Acoustics*, vol. 1(6), 209-214, 1977 doi:10.1049/tj-moa.1977.0029 .
- [16] T. Das, S. Chatterjee, "Harmonic Suppression by Using T-shaped Spur-Line in a Compact Hairpin-Line Bandpass Filter", *Radio Engineering*, vol. 30(2), pp 295-303, June 2021.